

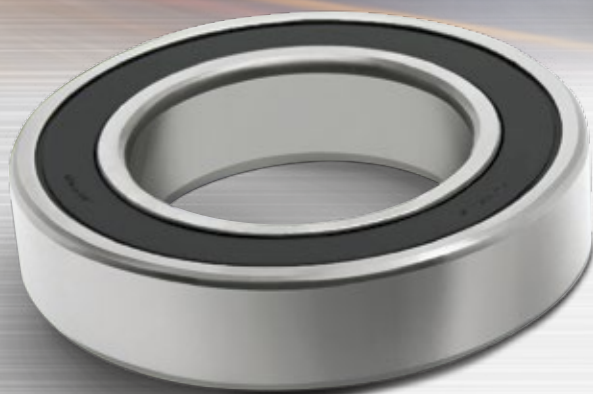

# EV/HEV用 グリース潤滑高速深溝玉軸受

**Grease Lubrication Type High Speed  
Deep Groove Ball Bearing for EV/HEV**

CAT.No.3040/JE

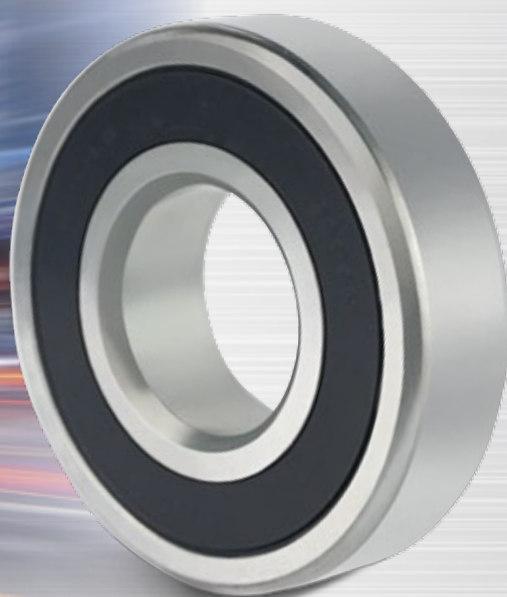

# 高速性能を向上させた EV/HEV用高速深溝玉軸受 標準軸受の2倍の許容回転速度を実現

High speed deep groove ball bearing for EV/HEV with improved high speed performance.  
Achieves 2X the allowable speed of standard bearings.



軽量高強度  
樹脂保持器

Lightweight and  
high strength  
resin cage

高速潤滑性能  
向上グリース

High speed lubricating  
performance  
improved grease

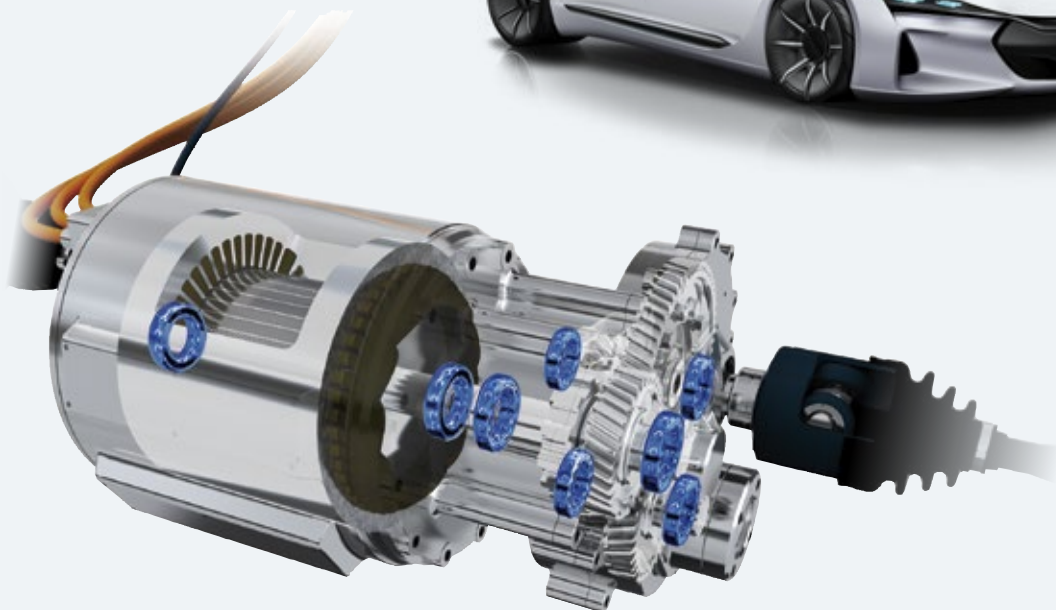

従来のグリース潤滑では、グリースが高速回転により飛び散り、軌道面への供給が不足し、本来のグリース性能が発揮できません。

EV/HEV用グリース潤滑高速深溝玉軸受は、高速回転用に開発した樹脂保持器とグリースを組み合わせ、最適なパフォーマンスをご提供します。

With conventional grease lubrication, high speed rotation causes grease spattering resulting in an insufficient supply of grease to the raceway surface so that the grease is unable to perform as it was originally intended.

Grease Lubrication Type High Speed Deep Groove Ball Bearing for EV/HEV combines a resin cage and grease developed for high speed rotation to provide optimal performance.

## ■ 特長 Feature

### 軽量高強度樹脂保持器

Lightweight and high strength resin cage

高速性・耐熱性・潤滑性を向上させた樹脂材料・形状の採用

Uses a resin material and design with high-speed, heat-resistant and high-lubrication properties

#### 慣性力の低減

Reduced inertial force

- ▶ 保持器の軽量化
- ▶ Lightweight cage

#### 遠心力変形の低減

Reduced centrifugal force deformation

- ▶ 材質と形状の最適化
- ▶ Optimized material and design

#### 潤滑性の改善

Improved lubricity

- ▶ ポケット形状の改良(グリース溝)  
グリースを保持し、軌道面への潤滑剤供給を確保
- ▶ Improved pocket design (Grease groove)  
Retains grease and ensures lubricant is supplied to the raceway surface

#### 回転トルク(温度上昇)の低減

Reduced rotational torque (temperature increase)

- ▶ 摩擦損失を低減させる形状
- ▶ Reduced friction loss design

耐熱性※1 Heat-resistant	材料強度※1 Material strength	遠心力変形※2 Centrifugal force deformation
30℃向上 30℃ improvement	1.6倍 1.6X	1/8

※1 標準樹脂保持器材料比 Compared with standard resin cage material  
※2 標準樹脂保持器比 Comparison with standard resin cage

### 高速潤滑性能向上グリース

High speed lubricating performance improved grease

広い温度範囲で高い潤滑性と低発熱を発揮するグリースを採用

Uses grease providing high lubricating and low heat generating properties over a wide range of temperatures

#### 潤滑性の改善

Improved lubricity

- ▶ グリース成分の最適化により、高速回転時の潤滑性を改善
- ▶ Optimization of grease composition improves lubricity during high speed rotation

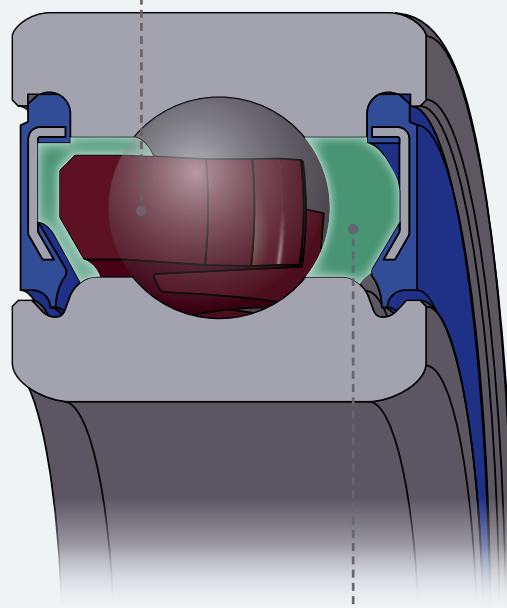

# 性能 Performance

## 軽量高強度樹脂保持器

高速回転時の遠心力変形を抑制し、高潤滑性、トルク低減、低昇温を可能にする形状と樹脂材料を採用

### Lightweight and high strength resin cage

A resin cage is used with a design and resin material that suppress centrifugal force deformation during high speed rotation, which enables high lubricity, torque reduction and low temperature rises

#### [温度上昇の低減] [Reduction in temperature rises]

##### 軸受温度上昇比較 (樹脂保持器比較)

Comparison of bearing temperature rise for resin cage

軸受寸法 Bearing dimensions	φ40×φ68×15
雰囲気温度 Ambient temperature	室温 Room temperature

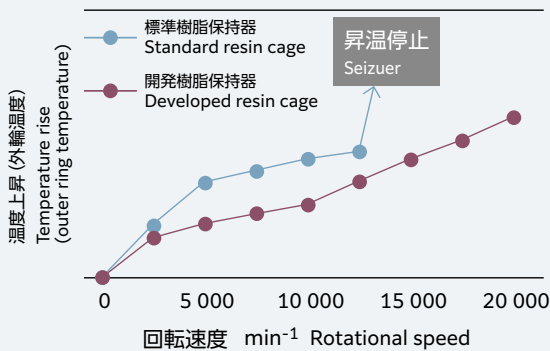

#### [回転トルクの低減] [Reduction in rotational torque]

##### 軸受回転トルク比較 (樹脂保持器比較)

Comparison of bearing rotational torque for resin cage

軸受寸法 Bearing dimensions	φ40×φ68×15
雰囲気温度 Ambient temperature	室温 Room temperature

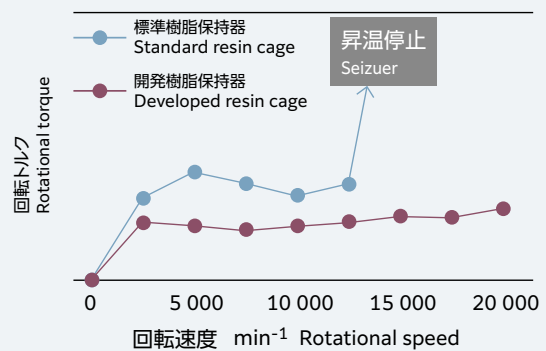

#### [遠心力変形量の低減] [Reduction in amount of centrifugal force deformation]

##### 樹脂保持器のポケット先端変形量比較 (解析)

Deformation amount comparison of pocket tip on resin cage (Analysis)

軸受寸法 Bearing dimensions	φ40×φ68×15
回転速度 Rotational speed	20 000min <sup>-1</sup>
温度 Temperature	120 °C

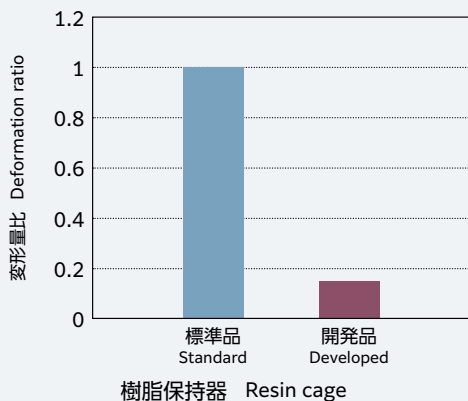

#### [潤滑性の改善] [Improvement in lubrication]

##### グリース溝有無によるグリース寿命比較

Grease life comparison with and without grease groove

軸受寸法 Bearing dimensions	φ40×φ68×15
回転速度 Rotational speed	20 000min <sup>-1</sup>
温度 Temperature	120 °C

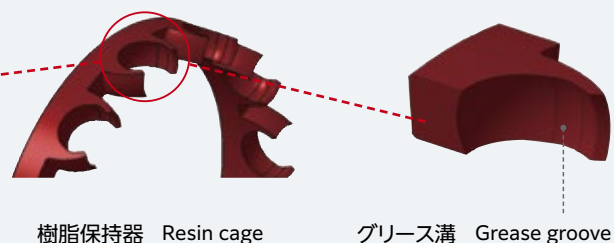
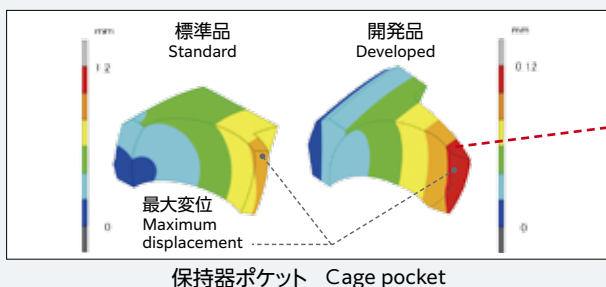
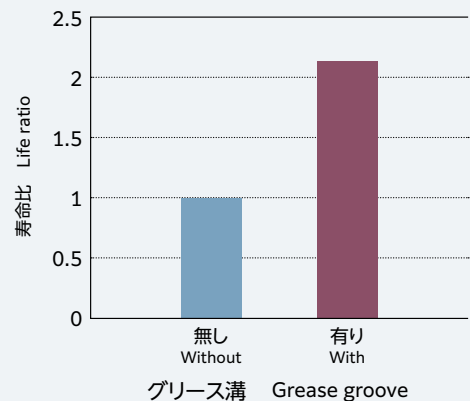

## 高速潤滑性向上グリース

高速回転時の潤滑性を考慮した組成  
高速回転時にもグリース本来の性能を発揮

High speed lubricating performance improved grease  
Composition that considers lubricity during high speed rotation  
Ensures the original grease performance even during high speed rotation

[潤滑性の改善] [Improvement in lubrication]

グリースの寿命比較 (開発樹脂保持器)

Comparison of grease life  
(Developed resin cage)

軸受寸法 Bearing dimensions	$\phi 40 \times \phi 68 \times 15$
回転速度 Rotational speed	$20\,000 \text{min}^{-1}$
温度 Temperature	$120\text{ }^{\circ}\text{C}$

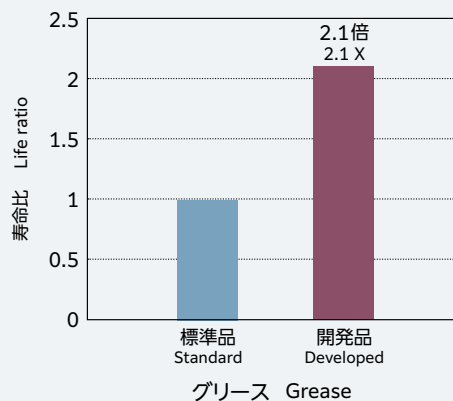

## シール

シールは、標準の非接触ゴムシールを採用  
標準シール形状を適用しましたが、使用環境や温度によって材質を選定します。

Seal  
Uses a standard non-contact rubber seal

This bearing is fitted with a standard-shaped seal. However, NTN selects the material that best suits the environment and temperature in which the bearing is to be used.

※ZZシールドの適用については、NTNにご相談ください。

\*Please contact NTN for ZZ shield applications.

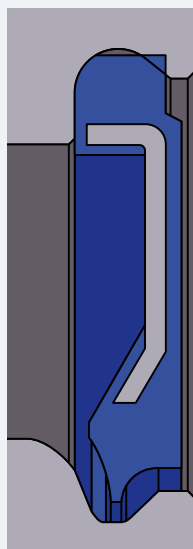



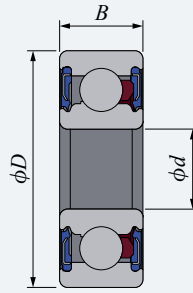

## ラインアップ

### Product lineup

基本番号 <sup>1)</sup> Basic number <sup>1)</sup>	主要寸法 Boundary dimensions [mm]			基本定格荷重 Basic load rating [kN]		疲労限荷重 <sup>2)</sup> Fatigue load limit <sup>2)</sup> [kN]	許容回転速度 <sup>3)</sup> Allowable speed <sup>3)</sup>
	<i>d</i>	<i>D</i>	<i>B</i>	<i>C<sub>r</sub></i>	<i>C<sub>or</sub></i>	<i>C<sub>u</sub></i>	[min <sup>-1</sup> ]
6900	10	22	6	2.99	1.27	0.099	67 500
6000		26	8	5.05	1.96	0.138	60 500
6202	15	35	11	8.60	3.60	0.279	43 000
6004C	20	42	12	11.8	5.40	0.500	34 500
63/22	22	56	16	20.4	9.25	0.725	27 500
6206	30	62	16	21.6	11.3	0.795	23 000
6306		72	19	29.5	15.0	1.14	21 000
6007	35	62	14	17.7	10.3	0.805	22 000
6207		72	17	28.4	15.3	1.09	20 000
6307		80	21	37.0	19.1	1.47	19 000
6008	40	68	15	18.6	11.5	0.890	20 000
6208		80	18	32.5	17.8	1.24	18 000
6308		90	23	45.0	24.0	1.83	16 500
6909	45	68	12	14.5	10.4	0.730	19 000
6009		75	16	23.2	15.1	1.16	18 000
6209		85	19	36.0	20.4	1.60	16 500
6309		100	25	58.5	32.0	2.50	14 500
6910	50	72	12	14.9	11.2	0.765	17 500
6010		80	16	24.2	16.6	1.24	16 500
6210		90	20	39.0	23.2	1.82	15 500
6310		110	27	68.5	38.5	2.99	13 000
6011	55	90	18	31.5	21.2	1.62	14 500
6211		100	21	48.0	29.2	2.29	13 500
6311		120	29	79.5	45.0	3.50	12 000

1) ラインアップにない基本番号・主要寸法についても対応可能です。詳細は、NTNにご照会ください。

2) 疲労限荷重 ( $C_u$ ) とは、軌道の最大荷重接触部で疲労応力となる、軸受にかかる荷重です。軸受の形式、内部諸元、品質、材料強度に依存し、ISO 281:2007では、高純度の軸受鋼製軸受において、 $C_u$ に相当する接触応力として1.5GPaを推奨しています。NTNでは、標準的な熱処理を施した軸受鋼製軸受について、各呼び番号に対する疲労限荷重の値を寸法表に記載し、寿命修正係数 $a_{ISO}$ を適用した修正定格寿命を算出可能としています。詳細については「転がり軸受総合カタログ (CAT.No.2203/J) 3.4 修正定格寿命」項をご参照ください。

3) 許容回転速度は、軸受温度120℃、ラジアル荷重0.05  $C_r$ 時の目安です。特殊環境下での使用については、NTNにご照会ください。

1) We can support basic numbers and boundary dimensions not listed in the product lineup. Please contact NTN for details.

2) The fatigue load limit is the applied load on a bearing that results in just reaching the fatigue stress limit at the maximum loaded raceway contact. This depends on the bearing type, internal specifications, quality, and material strength. In ISO 281:2007, 1.5GPa is recommended as the fatigue stress limit corresponding to  $C_u$  for bearings made of commonly used high quality material and good manufacturing quality. Values for the fatigue load limit with respect to the NTN bearing numbers are provided in the dimensional table. The life modification factor,  $a_{ISO}$ , should be evaluated considering the fatigue load limit. For details see catalog "Ball and Roller Bearings (CAT.No.2203/E) section 3.4 Modified rating life".

3) Allowable speed is an estimate when the bearing temperature is 120℃ and the radial load is 0.05  $C_r$ . Please contact NTN for usage in special environments.

減速機などでの使用を目的としたオイル潤滑の適用については、NTNにご照会ください。  
絶縁を目的としたセラミック玉軸受の適用については、NTNにご照会ください。

Please contact NTN for oil lubrication applications for use in speed reducers and such items.  
Please contact NTN for ceramic ball bearing applications for insulation.

## 呼び番号の例

Bearing number examples

# 6008 HSGT2 LLB CM / L542

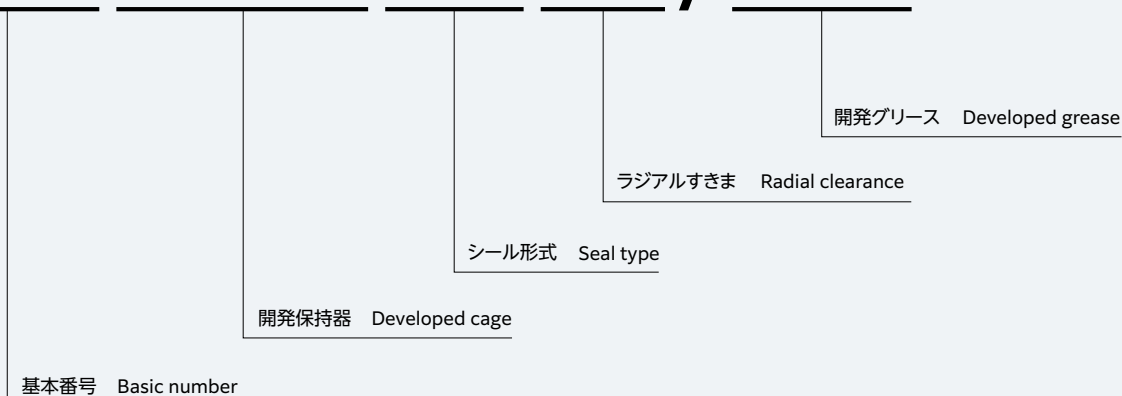

## 耐クリープオプション

Creep resistant option

耐クリープ性を向上させた、AC軸受とEC軸受の2種類の対応が可能

Can support two types, an AC bearing and EC bearing, to improve the creep resistance

### 【AC軸受】

[AC bearing]

標準の軸受と同じ主要寸法で、外輪外径に設けた二本の溝にOリングを装着した軸受

It has the same boundary dimensions as standard bearings with the addition of two O-ring imbedded on the outside surface of the outer ring

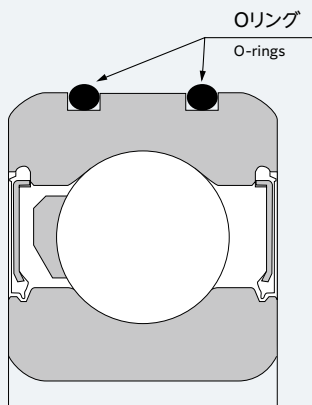

### 【EC軸受】

[EC bearing]

標準の軸受と同じ主要寸法で、外輪外径に設けた溝に熱膨張率の大きい高分子材料を成形した軸受

Boundary dimensions are same as for standard bearings, but formed polymer material with a high expansion rate is provided in the groove on the outer circumference of the outer ring

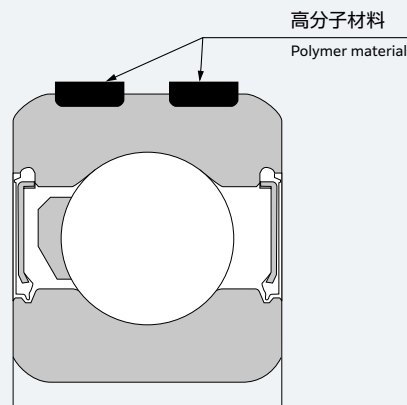

技術・価格・納期等のご照会・相談は最寄りの支社・営業所にお申し付けください。

営業拠点情報は  
こちら



NTN 株式会社

お問い合わせは

- カタログの内容については、技術的進歩および改良に対応するため製品の外観や仕様などは予告なしに変更することがあります。また、内容の正確さを維持するため、細心の注意を払っておりますが、万が一、誤記および製本上の落丁を起因とする損害が発生した場合の保証責任については負いかねます。
- The appearance and specifications may be changed without prior notice if required to improve performance. Although care has been taken to assure the accuracy of the data compiled in this catalog, NTN does not assume any liability to any company or person for errors or omissions.

**NTN®**