

# C-Lube Linear Roller Way Super MX Linear Roller Way Super X



# C-Lube Linear Roller Way Super MX

# MX



Aquamarine endplate for identification of C-Lube Linear Way

Track rail

Slide unit

End plate

Casing

Cylindrical rollers

Retaining plate

Grease nipple

Under seal

C-Lube

End seal

Linear Roller Way Super X

# LRX

## Features

### The roller type linear motion rolling guide achieves

#### the highest level of the performance

The superior characteristic of the roller makes linear motion rolling guide realize the most high-level performance in load capacity, rigidity, friction, every characteristic including running accuracy.

### Wide variation corresponding to needs

Five shapes of slide unit, flanged type, block type, side mounting type and etc. are lined up with four variations in length of slide unit with same section. They are available for optimal products to fit for requirement of machine and equipment.

### Extra high rigidity long unit

Extra high rigidity long type slide unit, which is 1.4 to 1.5 times rigid as standard slide unit, is serialized. Because number of rollers is increased, super high precise running performance is achieved, not only load capacity and rigidity.

### Stainless steel

The main metal components made of corrosion resistant stainless steel are available for small size from 10mm of track rail width. Therefore, they are most suitable for use in cleanroom environment and also for applications where the use of lubricants and rust preventive oil should be avoided or kept to a minimum.

### Easy replacement instead of ball type guide

Mounting dimensions are compatible as ball type Linear Way, MH and LWH series. Therefore, replacement to roller type is possible without design change of machine and equipment.

## Identification number and specification

The specification of MX and LRX series are identified by the identification number, which consists of a model code, a size, a part code, a preload symbol, a classification symbol, interchangeable code and optional supplemental codes.

Interchangeable specification	1	2	3	4	5	6	7	8	9	10
Slide unit only	MX	G	15	C1			T <sub>1</sub>	P	S1	/Z
Track rail only <sup>(1)</sup>	LRX		15		R240			P	S1	
Assembled set	MX	G	15	C2	R240		T <sub>1</sub>	P	S1	/Z

Non-interchangeable specification	1	2	3	4	5	6	7	8	9	10
Assembled set	MX	G	15	C2	R240		T <sub>1</sub>	P		/Z

- 1 Series Model code on page II-151
- 2 Length of slide unit Part code on page II-152
- 3 Size Size on page II-151
- 4 Number of slide unit Part code on page II-152
- 5 Length of track rail Material symbol on page II-152
- 6 Material Preload symbol on page II-155
- 7 Preload amount Classification symbol on page II-156
- 8 Accuracy class Interchangeable code on page II-157
- 9 Interchangeable Supplemental code on page II-157
- 10 Special specification

Note<sup>(1)</sup> : For the model code of a single track rail of interchangeable specification, indicate "LRX" regardless of the slide unit type to be combined.

MX · LRX

# Identification number and specification — Series · Length of slide unit · Size —

<b>1 Series</b>	C-Lube Linear Roller Way Super MX (MX Series)	Flange type mounting from top/bottom : MX <sup>(?)</sup> Block type mounting from top : MXD Compact block type mounting from top : MXS Low section flange type mounting from top : MXN Low section block type mounting from top : MXNS
	Linear Roller Way Super X <sup>(1)</sup> (LRX Series)	Flange type mounting from top/bottom : LRX <sup>(?)</sup> Block type mounting from top : LRXD Compact block type mounting from top : LRXS

Applicable size and shape of slide unit are shown in Table 1.1 and 1.2.  
For the model code of track rail of interchangeable specification, indicate "LRX" regardless of the slide unit type to be combined.

Note<sup>(1)</sup> : Linear Roller Way without C-Lube.  
Note<sup>(?)</sup> : MX20 (LRX20) can be mounted from top only. MXH20 (LRXH20) can be mounted from bottom, which has the same dimensions as those of above models.

<b>2 Length of slide unit</b>	Short : C	Applicable size and shape of slide unit are shown in Table 1.1 and 1.2.
	Standard : No symbol	
	High rigidity long : G	
	Extra high rigidity long : L	

<b>3 Size of rolling guide</b>	10, 12, 15, 20, 25, 30, 35, 45, 55, 65, 85, 100	Applicable size and shape of slide unit are shown in Table 1.1 and 1.2.
--------------------------------	---	---

Table 1.1 Model and size of MX and LRX

Material	Shape	Length of slide unit	Model code	Size											
				10	12	15	20	25	30	35	45	55	65	85	100
High carbon steel	Flange type mounted from top/bottom	Short	MXC	-	○	○	○ <sup>(1)</sup>	○	○	○	○	○	○	-	-
			LRXC	-	○	○	○ <sup>(1)</sup>	○	○	○	○	○	○	-	-
		Standard	MX	-	○	○	○ <sup>(1)</sup>	○	○	○	○	○	○	-	-
			LRX	-	○	○	○ <sup>(1)</sup>	○	○	○	○	○	○	-	-
		High rigidity long	MXG	-	○	○	○ <sup>(1)</sup>	○	○	○	○	○	○	-	-
			LRXG	-	○	○	○ <sup>(1)</sup>	○	○	○	○	○	○	-	-
	Extra high rigidity long	MXL	-	-	-	○ <sup>(1)</sup>	○	○	○	○	○	○	-	-	
		LRXL	-	-	-	-	-	-	-	-	-	○	-	-	
	Block type mounted from top	Short	MXDC	-	○	○	○	○	○	○	○	○	-	-	
			LRXDC	-	○	○	○	○	○	○	○	○	○	-	-
		Standard	MXD	-	○	○	○	○	○	○	○	○	○	-	-
			LRXD	-	○	○	○	○	○	○	○	○	○	-	-
		High rigidity long	MXDG	-	○	○	○	○	○	○	○	○	○	-	-
			LRXDG	-	○	○	○	○	○	○	○	○	○	-	-
Extra high rigidity long	MXDL	-	-	-	○	○	○	○	○	○	-	-			

Note<sup>(1)</sup> : MXC20, MX20, MXG20, MXL20, LRXC20, LRX20, LRXG20 can be mounted from top. Models that can be mounted with same dimensions are MXHC20, MXH20, MXHG20, MXHL20, LRXC20, LRXH20, LRXHG20.  
Remark : The mark  indicates that interchangeable specification is available.

# — Number of slide units · Length of track rail · Material —

<b>4 Number of slide units</b>	: C○	For an assembled set, indicates the number of slide units assembled on one track rail. For an interchangeable slide unit only, "C1" can be indicated.
	: R○	Indicate the length of track rail in mm. For standard and maximum lengths, see Table 2.1, 2.2, 2.3, 2.4.
<b>6 Material</b>	High carbon steel : No symbol	Applicable types and sizes are shown in, Tables 1.1 and 1.2.
	Stainless steel : SL	

Table 1.2 Model and size of MX and LRX

Material	Shape	Length of slide unit	Model code	Size											
				10	12	15	20	25	30	35	45	55	65	85	100
High carbon steel	Compact block type mounting from top	Short	MXSC	-	-	○	○	○	○	-	-	-	-	-	
			LRXSC	-	-	○	○	○	○	-	-	-	-	-	
		Standard	MXS	-	-	○	○	○	○	○	○	○	-	-	
			LRXS	-	-	○	○	○	○	-	-	-	-	-	
		High rigidity long	MXSG	-	-	○	○	○	○	○	○	-	-		
			LRXSG	-	-	○	○	○	○	-	-	-	-		
	Extra high rigidity long	MXSL	-	-	-	○	○	○	-	-	-	-			
	Low section flange type mounting from top	Standard	MXN	-	-	-	-	○	○	○	○	-	-		
		High rigidity long	MXNG	-	-	-	-	○	○	○	○	-	-		
		Extra high rigidity long	MXNL	-	-	-	-	○	○	○	○	-	-		
		Low section block type mounting from top	Standard	MXNS	-	-	-	-	○	○	○	○	-	-	
	High rigidity long		MXNSG	-	-	-	-	○	○	○	○	-	-		
	Extra high rigidity long		MXNSL	-	-	-	-	○	○	○	○	-	-		
	Stainless steel	Block type mounting from top	Short	LRXDC...SL	-	○	○	○	○	○	-	-	-	-	
Standard			MXD...SL	-	○	○	○	○	○	-	-	-	-		
High rigidity long			LRXD...SL	○	○	○	○	○	○	-	-	-	-		
			LRXDG...SL	-	○	○	○	○	○	-	-	-			

Remark : The mark  indicates that interchangeable specification is available.

Table 2.1 Standard and maximum lengths of high carbon steel track rails



Item	Model number	MX 12 LRX12	MX 15 LRX15	MX 20 LRX20	MX 25 LRX25	MX 30 LRX30	MX 35 LRX35
Standard length $L(n)$		80 ( 2 )	180 ( 3 )	240 ( 4 )	240 ( 4 )	480 ( 6 )	480 ( 6 )
		160 ( 4 )	240 ( 4 )	480 ( 8 )	480 ( 8 )	640 ( 8 )	640 ( 8 )
		240 ( 6 )	360 ( 6 )	660 (11)	660 (11)	800 (10)	800 (10)
		320 ( 8 )	480 ( 8 )	840 (14)	840 (14)	1 040 (13)	1 040 (13)
		400 (10)	660 (11)	1 020 (17)	1 020 (17)	1 200 (15)	1 200 (15)
		480 (12)		1 200 (20)	1 200 (20)	1 520 (19)	1 520 (19)
		560 (14)		1 500 (25)	1 500 (25)		
		640 (16)					
		720 (18)					
	Pitch of mounting holes $F$		40	60	60	60	80
$E$		20	30	30	30	40	40
Standard range of $E^{(1)}$	incl.	5.5	7	8	9	10	10
	under	25.5	37	38	39	50	50
Maximum length <sup>(2)</sup>		1 480	1 500 (1 980)	1 980 (3 000)	3 000 (3 960)	2 960 (4 000)	2 960 (4 000)
Item	Model number	MX 45 LRX45	MX 55 LRX55	MX 65 LRX65	LRX85	LRXG100	
Standard length $L(n)$		840 ( 8 )	840 ( 7 )	1 500 (10)	1 620 ( 9 )	1 500 (10)	
		1 050 (10)	1 200 (10)	1 950 (13)	1 980 (11)	1 950 (13)	
		1 260 (12)	1 560 (13)	3 000 (20)	2 340 (13)	3 000 (20)	
		1 470 (14)	1 920 (16)		2 700 (15)		
		1 995 (19)	3 000 (25)				
Pitch of mounting holes $F$		105	120	150	180	150	
$E$		52.5	60	75	90	75	
Standard range of $E^{(1)}$	incl.	12.5	15	17	23	29	
	under	65	75	92	113	104	
Maximum length <sup>(2)</sup>		2 940 (3 990)	3 000 (3 960)	3 000 (3 900)	2 880	3 000	

Notes<sup>(1)</sup> : Not applicable to the track rail with female threads for bellows (supplemental code "/J").  
<sup>(2)</sup> : Track rails with the maximum lengths shown in parentheses can also be manufactured. Consult **IKO** for further information.  
 Remarks 1 : For half pitch of track rail mounting holes (supplemental code "/HP"), refer to Table 2.3.  
 2 : For the model code of track rail of interchangeable specification, indicate "LRX" regardless of the slide unit type to be combined.  
 3 : The above table shows representative model numbers but is applicable to all models of the same size.

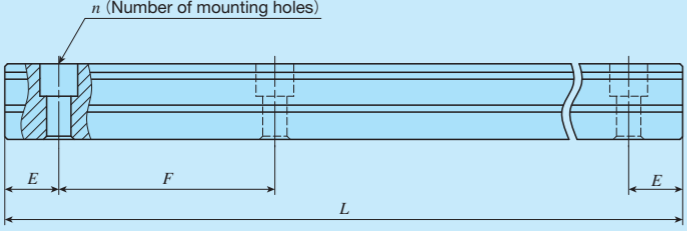
Table 2.2 Standard and maximum lengths of stainless steel track rail

Item	Model number	LRXD10...SL	MX 12...SL LRX12...SL	MX 15...SL LRX15...SL	MX 20...SL LRX20...SL	MX 25...SL LRX25...SL	MX 30...SL LRX30...SL
Standard length $L(n)$		50 ( 2 )	80 ( 2 )	180 ( 3 )	240 ( 4 )	240 ( 4 )	480 ( 6 )
		100 ( 4 )	160 ( 4 )	240 ( 4 )	480 ( 8 )	480 ( 8 )	640 ( 8 )
		150 ( 6 )	240 ( 6 )	360 ( 6 )	660 (11)	660 (11)	800 (10)
		200 ( 8 )	320 ( 8 )	480 ( 8 )	840 (14)	840 (14)	1 040 (13)
		250 (10)	400 (10)	660 (11)			
		300 (12)	480 (12)				
		350 (14)	560 (14)				
		400 (16)	640 (16)				
		450 (18)	720 (18)				
		500 (20)					
Pitch of mounting holes $F$		25	40	60	60	60	80
$E$		12.5	20	30	30	30	40
Standard range of $E^{(1)}$	incl.	5	5.5	7	8	9	10
	under	17.5	25.5	37	38	39	50
Maximum length <sup>(2)</sup>		850 (1 000)	1 000 (1 480)	1 200 (1 980)	1 200 (1 980)	1 200 (1 980)	1 200 (2 000)

Notes<sup>(1)</sup> : Not applicable to the track rail with female threads for bellows (supplemental code "/J").  
<sup>(2)</sup> : Track rails with the maximum lengths shown in parentheses can also be manufactured. Consult **IKO** for further information.  
 Remarks 1 : For half pitch of track rail mounting holes (supplemental code "/HP"), refer to Table 2.4.  
 2 : For the model code of track rail of interchangeable specification, indicate "LRX" regardless of the slide unit type to be combined.  
 3 : The above table shows representative model numbers but is applicable to all models of the same size.

Table 2.3 Standard and maximum lengths of high carbon steel track rail (Half pitch of track rail mounting holes specification /HP)

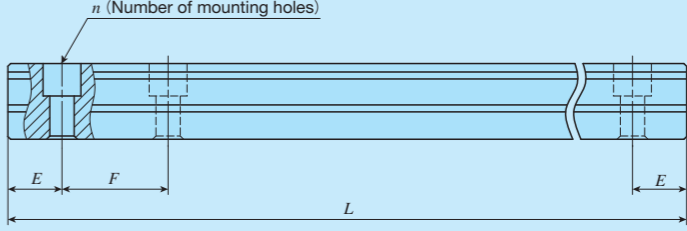

Item	Model number	MX 12.../HP LRX12.../HP	MX 15.../HP LRX15.../HP	MX 20.../HP LRX20.../HP	MX 25.../HP LRX25.../HP	MX 30.../HP LRX30.../HP	MX 35.../HP LRX35.../HP
Standard length $L(n)$		80 ( 4 )	180 ( 6 )	240 ( 8 )	480 (16)	480 (12)	480 (12)
		160 ( 8 )	240 ( 8 )	480 (16)	660 (22)	640 (16)	640 (16)
		240 (12)	360 (12)	660 (22)	840 (28)	800 (20)	800 (20)
		320 (16)	480 (16)	840 (28)	1 020 (34)	1 040 (26)	1 040 (26)
		400 (20)	660 (22)	1 020 (34)	1 200 (40)	1 200 (30)	1 200 (30)
		480 (24)		1 200 (40)	1 500 (50)	1 520 (38)	1 520 (38)
		560 (28)		1 500 (50)			
		640 (32)					
		720 (36)					
	Pitch of mounting holes $F$		20	30	30	30	40
$E$		10	15	15	15	20	20
Standard range of $E^{(1)}$	incl.	5.5	7	8	9	10	10
	under	15.5	22	23	24	30	30
Maximum length <sup>(2)</sup>		1 480	1 500 (1 980)	1 980 (3 000)	3 000 (3 960)	2 960 (4 000)	2 960 (4 000)
Item	Model number	MX 45.../HP LRX45.../HP	MX 55.../HP LRX55.../HP	MX 65.../HP LRX65.../HP	LRX85.../HP		
Standard length $L(n)$		840 (16)	840 (14)	1 500 (20)	1 620 (18)		
		1 050 (20)	1 200 (20)	1 950 (26)	1 980 (22)		
		1 260 (24)	1 560 (26)	3 000 (40)	2 340 (26)		
		1 470 (28)	1 920 (32)		2 700 (30)		
		1 995 (38)	3 000 (50)				
Pitch of mounting holes $F$		52.5	60	75	90		
$E$		26.25	30	37.5	45		
Standard range of $E^{(1)}$	incl.	12.5	15	17	23		
	under	38.75	45	54.5	68		
Maximum length <sup>(2)</sup>		2 940 (3 990)	3 000 (3 960)	3 000 (3 900)	2 970		

Notes<sup>(1)</sup> : Not applicable to the track rail with female threads for bellows (supplemental code "/J").  
<sup>(2)</sup> : Track rails with the maximum lengths shown in parentheses can also be manufactured. Consult **IKO** for further information.  
 Remarks 1 : The above table shows representative model numbers but is applicable to all models of the same size.  
 2 : For the model code of track rail of interchangeable specification, indicate "LRX" regardless of the slide unit type to be combined.

Table 2.4 Standard and maximum lengths of Stainless steel track rail (Half pitch of track rail mounting holes specification /HP)

Item	Model number	MX 12...SL/HP LRX12...SL/HP	MX 15...SL/HP LRX15...SL/HP	MX 20...SL/HP LRX20...SL/HP	MX 25...SL/HP LRX25...SL/HP	MX 30...SL/HP LRX30...SL/HP
Standard length $L(n)$		80 ( 4 )	180 ( 6 )	240 ( 8 )	480 (16)	480 (12)
		160 ( 8 )	240 ( 8 )	480 (16)	660 (22)	640 (16)
		240 (12)	360 (12)	660 (22)	840 (28)	800 (20)
		320 (16)	480 (16)	840 (28)		1 040 (26)
		400 (20)	660 (22)			
		480 (24)				
		560 (28)				
		640 (32)				
		720 (36)				
	Pitch of mounting holes $F$		20	30	30	30
$E$		10	15	15	15	20
Standard range of $E^{(1)}$	incl.	5.5	7	8	9	10
	under	15.5	22	23	24	30
Maximum length <sup>(2)</sup>		1 000 (1 480)	1 200 (1 980)	1 200 (1 980)	1 200 (1 980)	1 200 (2 000)

Notes<sup>(1)</sup> : Not applicable to the track rail with female threads for bellows (supplemental code "/J").  
<sup>(2)</sup> : Track rails with the maximum lengths shown in parentheses can also be manufactured. Consult **IKO** for further information.  
 Remarks 1 : The above table shows representative model numbers but is applicable to all models of the same size.  
 2 : For the model code of track rail of interchangeable specification, indicate "LRX" regardless of the slide unit type to be combined.



**7 Preload amount**

Standard	: No symbol	Specify this item for an assembled set or a single slide unit.
Light preload	: T <sub>1</sub>	
Medium preload	: T <sub>2</sub>	For applicable preload amount, see Table 3. For details of preload amount, see Table 4.
Heavy preload	: T <sub>3</sub>	

**Table 3 Preload amount**

Preload type	Item	Symbol	Preload amount N	Application
Standard	(No Symbol)		0 <sup>(1)</sup>	· Very smooth motion
Light preload	T <sub>1</sub>		0.02 C <sub>0</sub>	· Minimum vibration · Load is evenly balanced · Smooth and precise motion
Medium preload	T <sub>2</sub>		0.05 C <sub>0</sub>	· Medium vibration · Medium overhung load
Heavy preload	T <sub>3</sub>		0.08 C <sub>0</sub>	· Vibration and / or shocks · Large overhung load · Heavy cutting

Note<sup>(1)</sup> : Zero or minimal amount of preload.  
Remark : C<sub>0</sub> means the basic static load rating.

**Table 4 Applicable preload**

Size	Preload class and code			
	Standard (No symbol)	Light preload (T <sub>1</sub> )	Medium preload (T <sub>2</sub> )	Heavy preload (T <sub>3</sub> )
10	○	○	—	—
12	○	○	○	○
15	○	○	○	○
20	○	○	○	○
25	○	○	○	○
30	○	○	○	○
35	○	○	○	○
45	○	○	○	○
55	○	○	○	○
65	○	○	○	○
85	○	○	○	○
100	○	○	○	○

Remark : The mark  indicates that interchangeable specification is available.

**8 Accuracy class**

High	: H	Super precision class (SP) and Ultra precision class (UP) are applicable to Non-interchangeable products only. In the interchangeable specification, please combine the same accuracy codes on both slide unit and track rail.
Precision	: P	For detail of accuracy, see Table 5.
Super precision	: SP	Applicable sizes are shown in Table 6.
Ultra precision	: UP	

**Table 5 Accuracy**

unit : mm

Classification(symbol)	High (H)	Precision (P)	Super precision (SP)	Ultra precision (UP)
Item				
Dim. H tolerance	±0.040	±0.020	±0.010	±0.008
Dim. N tolerance	±0.050	±0.025	±0.015	±0.010
Dim. variation of H <sup>(1)</sup>	0.015	0.007	0.005	0.003
Dim. variation of N <sup>(1)</sup>	0.020	0.010	0.007	0.003
Dim. variation of H for multiple assembled sets <sup>(2)</sup>	0.035	0.025	—	—
Parallelism in operation of C to A	See Fig. 1.			
Parallelism in operation of D to B	See Fig. 1.			

Notes<sup>(1)</sup> : It means the size variation between slide units mounted on the same track rail.  
<sup>(2)</sup> : Applicable to the interchangeable specification.

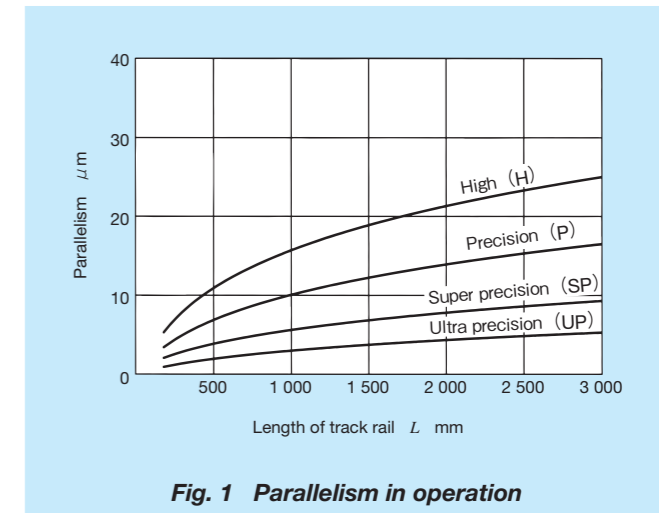

**Fig. 1 Parallelism in operation**

**Table 6 Accuracy class and size**

Size	Accuracy class			
	High (H)	Precision (P)	Super precision (SP)	Ultra precision (UP)
10	○	○	○	○
12	○	○	○	○
15	○	○	○	○
20	○	○	○	○
25	○	○	○	○
30	○	○	○	○
35	○	○	○	○
45	○	○	○	○
55	○	○	○	○
65	○	○	○	○
85	○	○	○	○
100	○	○	○	○

Remark : The mark  indicates that interchangeable specification is available.

<b>9 Interchangeable specification</b>	Interchangeable	: S1 : S2	Specify this code for the interchangeable specification products. Assemble track rails and slide units with the same interchangeable code.
	Non-Interchangeable	: No symbol	For applicable models and sizes, see Table 1.1 and 1.2.

<b>10 Special specification</b>	/A, /D, /E, /F, /GE, /HP, /I, /JO, /LO, /LFO, /MA, /MN, /N, /PS, /Q, /RCO, /T, /UR, /VO, /WO, /YO, /ZO	For applicable special specifications, see Table 7.1, 7.2, 7.3, 7.4. When several special specifications are combined, see Table 8. For details of special specifications, see page III-28.
---------------------------------	--	---

**Table 7.1 Special specifications (Interchangeable specification, Single slide units)**

Optional specification	Supplemental code	Size											
		10	12	15	20	25	30	35	45	55	65	85	100
Changed pitch of slide unit middle mounting holes <sup>(1)</sup>	/GE	—	×	○	○	○	○	○	○	○	○	—	—
Female threads for bellows <sup>(2)</sup>	/JO	—	×	○	○	○	○	○	○	○	○	—	—
No end seal <sup>(3)</sup>	/N	—	○	○	○	○	○	○	○	×	×	—	—
C-Lube plates <sup>(4)</sup>	/Q	—	○	○	○	○	○	○	○	○	○	—	—
Double end seals	/VO	—	○	○	○	○	○	○	○	○	○	—	—
Scrapers	/ZO	—	○	○	○	○	○	○	○	○	○	—	—

Notes<sup>(1)</sup> : Applicable to MX, MXG, MXH20, MXHG20, LRX, LRXG, LRXH20, and LRXHG20. (Flange types).  
<sup>(2)</sup> : Not applicable to stainless steel model.  
<sup>(3)</sup> : Not applicable to low section frange and block types.  
<sup>(4)</sup> : Applicable to LRX series

**Table 7.2 Special specifications (Interchangeable specification, track rail)**

Optional specification	Supplemental code	Size											
		10	12	15	20	25	30	35	45	55	65	85	100
Specified rail mounting hole positions	/E	—	○	○	○	○	○	○	○	○	○	—	—
Caps for rail mounting holes	/F	—	○	○	○	○	○	○	○	○	○	—	—
Half pitch of track rail mounting holes	/HP	—	○	○	○	○	○	○	○	○	○	—	—
Female threads for bellows <sup>(1)</sup>	/JO	—	×	○	○	○	○	○	○	○	○	—	—
Black chrome surface treatment	/LO	—	○	○	○	○	○	○	○	○	○	—	—
Without track rail mounting bolts	/MN	—	○	○	○	○	○	○	○	○	○	—	—
Butt-jointing interchangeable track rail	/T	—	○	○	○	○	○	○	○	○	○	—	—

Note<sup>(1)</sup> : Not applicable to stainless steel model.

**Table 7.3 Special specifications (Interchangeable specification, assembled set)**

Optional specification	Supplemental code	Size											
		10	12	15	20	25	30	35	45	55	65	85	100
Opposite reference surfaces arrangement	/D	—	○	○	○	○	○	○	○	○	○	—	—
Specified rail mounting hole positions	/E	—	○	○	○	○	○	○	○	○	○	—	—
Caps for rail mounting holes	/F	—	○	○	○	○	○	○	○	○	○	—	—
Changed pitch of slide unit middle mounting holes <sup>(1)</sup>	/GE	—	×	○	○	○	○	○	○	○	○	—	—
Half pitch of track rail mounting holes	/HP	—	○	○	○	○	○	○	○	○	○	—	—
Female threads for bellows <sup>(2)</sup>	/JO	—	×	○	○	○	○	○	○	○	○	—	—
Black chrome surface treatment	/LO	—	○	○	○	○	○	○	○	○	○	—	—
Fluorine black chrome surface treatment	/LFO	—	○	○	○	○	○	○	○	○	○	—	—
With track rail mounting bolts <sup>(3)</sup>	/MA	—	○	○	○	○	○	○	○	○	○	—	—
Without track rail mounting bolts <sup>(3)</sup>	/MN	—	○	○	○	○	○	○	○	○	○	—	—
No end seal <sup>(5)</sup>	/N	—	○	○	○	○	○	○	○	○	×	×	—
C-Lube plates <sup>(4)</sup>	/Q	—	○	○	○	○	○	○	○	○	○	—	—
Butt-jointing interchangeable track rail	/T	—	○	○	○	○	○	○	○	○	○	—	—
Double end seals	/VO	—	○	○	○	○	○	○	○	○	○	—	—
Specified grease <sup>(4)</sup>	/YO	—	○	○	○	○	○	○	○	○	○	—	—
Scrapers	/ZO	—	○	○	○	○	○	○	○	○	○	—	—

Notes<sup>(1)</sup> : Applicable to MX, MXG, MXH20, MXHG20, LRX, LRXG, LRXH20, and LRXHG20 (Flange types).  
<sup>(2)</sup> : Not applicable to stainless steel model.  
<sup>(3)</sup> : Applicable to MX series  
<sup>(4)</sup> : Applicable to LRX series  
<sup>(5)</sup> : Not applicable to low section frange and block types.

**Table 7.4 Special specifications (Non interchangeable specification)**

Optional specification	Supplemental code	Size											
		10	12	15	20	25	30	35	45	55	65	85	100
Butt-jointing track rails	/A	○	○	○	○	○	○	○	○	○	○	○	○
Opposite reference surfaces arrangement	/D	○	○	○	○	○	○	○	○	○	○	○	○
Specified rail mounting hole positions	/E	○	○	○	○	○	○	○	○	○	○	○	○
Caps for rail mounting holes	/F	×	○	○	○	○	○	○	○	○	○	○	○
Changed pitch of slide unit middle mounting holes <sup>(1)</sup>	/GE	×	×	○	○	○	○	○	○	○	○	×	○
Half pitch of track rail mounting holes	/HP	×	○	○	○	○	○	○	○	○	○	○	×
Inspection sheet	/I	○	○	○	○	○	○	○	○	○	○	○	○
Female threads for bellows	/JO	×	×	○	○	○	○	○	○	○	○	○	×
Black chrome surface treatment	/LO	×	○	○	○	○	○	○	○	○	○	×	×
Fluorine black chrome surface treatment	/LFO	×	○	○	○	○	○	○	○	○	○	×	×
With track rail mounting bolts <sup>(2)</sup>	/MA	×	○	○	○	○	○	○	○	○	○	×	×
Without track rail mounting bolts <sup>(3)</sup>	/MN	○	○	○	○	○	○	○	○	○	○	○	○
No end seal <sup>(4)</sup>	/N	○	○	○	○	○	○	○	○	○	×	×	×
Rail cover plate for track rail <sup>(3)</sup>	/PS	×	×	×	×	×	×	○	○	○	×	×	×
C-Lube plates <sup>(3)</sup>	/Q	○	○	○	○	○	○	○	○	○	○	○	×
C-Wiper <sup>(2) (5)</sup>	/RCO	×	×	×	○	○	○	○	○	○	○	×	×
Inner seal <sup>(2)</sup>	/UR	×	×	×	○	○	○	○	○	○	○	×	×
Double end seals	/VO	—	○	○	○	○	○	○	○	○	○	○	○
Matched sets to be used as an assembled group	/WO	○	○	○	○	○	○	○	○	○	○	×	×
Specified grease <sup>(3)</sup>	/YO	○	○	○	○	○	○	○	○	○	○	○	○
Scrapers	/ZO	—	○	○	○	○	○	○	○	○	○	○	○

Notes<sup>(1)</sup> : Applicable to MX, MXG, MXH20, MXHG20, LRX, LRXG, LRXH20, and LRXHG20 (Flange types).  
<sup>(2)</sup> : Applicable to MX series  
<sup>(3)</sup> : Applicable to LRX series  
<sup>(4)</sup> : Not applicable to low section frange and block types.  
<sup>(5)</sup> : /RC includes /UR and /Z as standard.



Table 10.2 Female threads for bellows (For single slide unit /J, For assembled set /J /JJ)

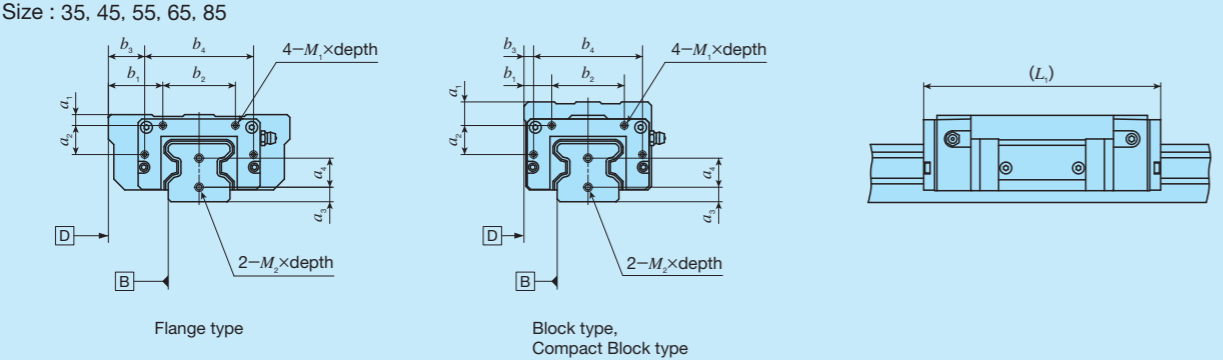

Model number		Slide unit								Track rail		
		$a_1$	$a_2$	$b_1$	$b_2$	$b_3$	$b_4$	$M_1 \times \text{depth}$	$L_1^{(1)}$	$a_3$	$a_4$	$M_2 \times \text{depth}$
MXC 35	LRXC 35	6	16	30	20	60	M3 × 6	99	8	16	M4 × 8	
MX 35	LRX 35							131				
MXG 35	LRXG 35							159				
MXL 35	—							191				
MXDC 35	LRXDC 35	13	15	40	5	60	M3 × 6	99	8	16	M4 × 8	
MXD 35	LRXD 35							131				
MXDG 35	LRXDG 35							159				
MXDL 35	—							191				
MXS 35	—	6	15	40	5	60	M3 × 6	131	8	16	M4 × 8	
MXSG 35	—							159				
MXC 45	LRXC 45	7	21	35	23	74	M4 × 8	123	10	19	M5 × 10	
MX 45	LRX 45							163				
MXG 45	LRXG 45							203				
MXL 45	—							243				
MXDC 45	LRXDC 45	17	18	50	6	74	M4 × 8	123	10	19	M5 × 10	
MXD 45	LRXD 45							163				
MXDG 45	LRXDG 45							203				
MXDL 45	—							243				
MXS 45	—	7	18	50	6	74	M4 × 8	163	10	19	M5 × 10	
MXSG 45	—							203				
MXC 55	LRXC 55	7	27	40	26	88	M4 × 8	145	10	24	M5 × 10	
MX 55	LRX 55							193				
MXG 55	LRXG 55							247				
MXL 55	—							301				
MXDC 55	LRXDC 55	17	20	60	6	88	M4 × 8	145	10	24	M5 × 10	
MXD 55	LRXD 55							193				
MXDG 55	LRXDG 55							247				
MXDL 55	—							301				
MXS 55	—	7	20	60	6	88	M4 × 8	193	10	24	M5 × 10	
MXSG 55	—							247				
MXC 65	LRXC 65	8.7	37	47.5	31	108	M5 × 10	191	14	28	M6 × 12	
MX 65	LRX 65							255				
MXG 65	LRXG 65							319				
MXL 65	—							320				
MXDC 65	LRXDC 65	8.7	37	75	9	108	M5 × 10	391	14	28	M6 × 12	
MXD 65	LRXD 65							191				
MXDG 65	LRXDG 65							192				
MXDL 65	—							255				
—	LRX 85	15	45	62.5	90	37.5	M6 × 10	256	14.5	38	M6 × 12	
—	LRXG 85							319				
—	LRXL 85							320				
—	—							391				

unit : mm

Note<sup>(1)</sup> : The values for the slide unit with female threads for bellow mounting at the both ends.

Table 10.3 Female threads for bellow mounting (For single slide unit /J, For assembled set /J /JJ)

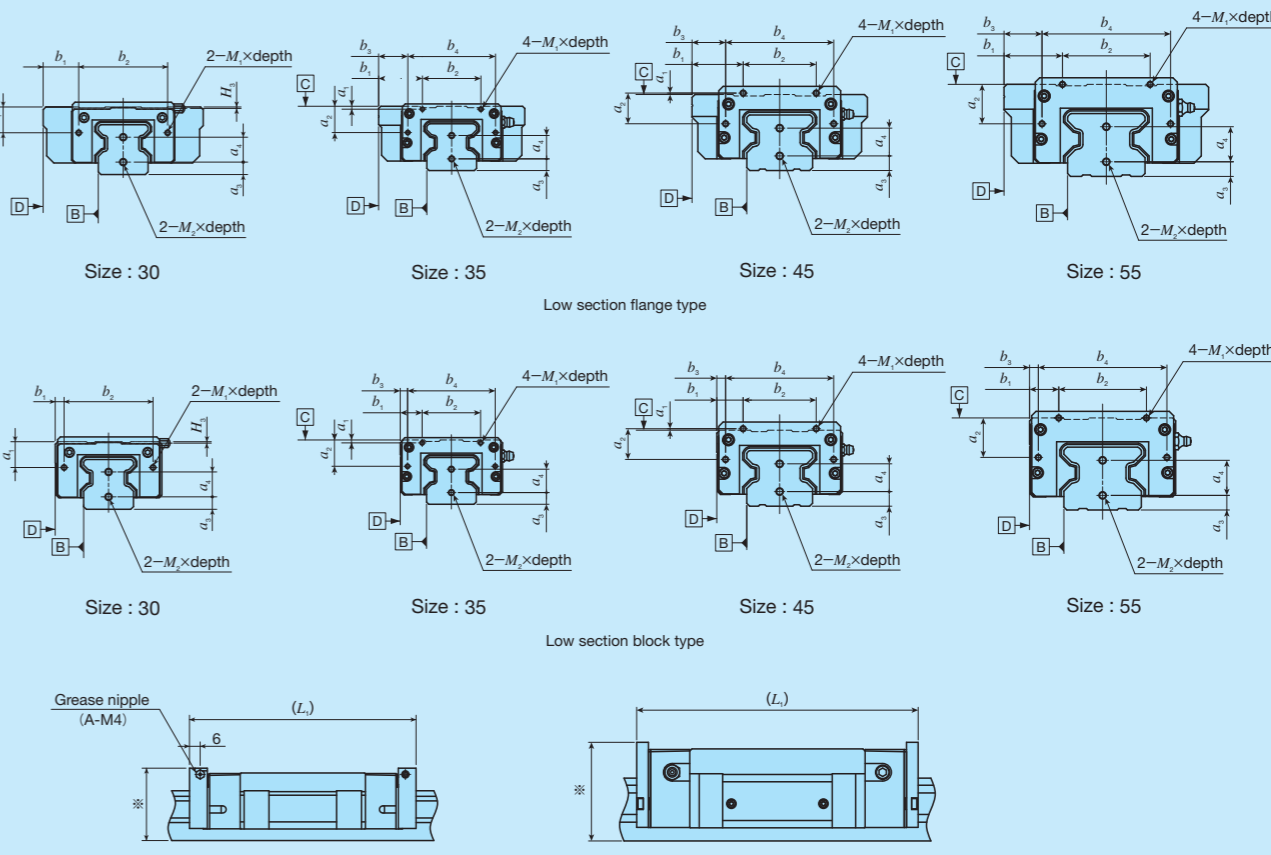

Model number		Slide unit								Track rail			
		$a_1^{(1)}$	$a_2$	$b_1$	$b_2$	$b_3$	$b_4$	$M_1 \times \text{depth}$	$L_1^{(2)}$	$H_3$	$a_3$	$a_4$	$M_2 \times \text{depth}$
MXN 30	MXNG 30	14.5	—	20	50	—	—	M3 × 6	128	0.8	7	14	M4 × 8
MXNL 30	MXNSL 30								177				
MXNS 30	MXNSG 30			128									
MXNSL 30	MXNSL 30			149									
MXNSG 30	MXNSG 30			177									
MXN 35	MXNG 35	2	16	30	40	60	M3 × 6	131	—	8	16	M4 × 8	
MXNL 35	MXNSL 35							159					
MXNS 35	MXNSG 35			191									
MXNSL 35	MXNSL 35			131									
MXNSG 35	MXNSG 35			159									
MXN 45	MXNG 45	1	21	35	50	74	M4 × 8	163	—	10	19	M5 × 10	
MXNL 45	MXNSL 45							203					
MXNS 45	MXNSG 45			243									
MXNSL 45	MXNSL 45			163									
MXNSG 45	MXNSG 45			203									
MXN 55	MXNG 55	0	27	40	60	88	M4 × 8	193	—	10	24	M5 × 10	
MXNL 55	MXNSL 55							247					
MXNS 55	MXNSG 55			301									
MXNSL 55	MXNSL 55			193									
MXNSG 55	MXNSG 55			247									

unit : mm

Notes<sup>(1)</sup> : Values  $a_1$  are the dimension between C-surface (upper surface of slide unit) and the center of female thread.

<sup>(2)</sup> : The values for the slide unit with female threads for bellow mounting at the both ends.

Remark : The dimension marked ※ is higher than H dimension. For details, consult IKO for future information.



**Table 11.1 Slide unit with C-Lube plates (Supplemental code /Q)**

Size : 10, 12, 15, 20, 25, 30

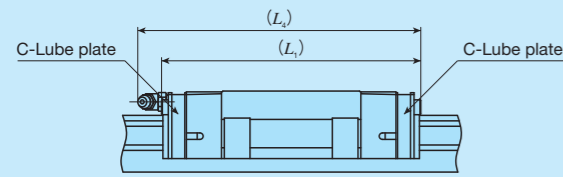

unit : mm

Model number	$L_1$	$L_4$
LRXD 10...SL	43.5	—
LRXC 12	47	50
LRX 12	57	60
LRXG 12	68	71
LRXC 15	63	64
LRX 15	79	80
LRXG 15	95	96
LRXC 20	76	84
LRX 20	96	104
LRXG 20	116	124
LRXC 25	85	93
LRX 25	109	117
LRXG 25	124	132
LRXC 30	96	107
LRX 30	124	135
LRXG 30	145	156

Remarks 1 : The values for the slide unit with C-Lube plates at both ends.

2 : The table shows representative model numbers only and is also applicable to all models in the same size.

**Table 11.2 Slide unit with C-Lube plates (Supplemental code /Q)**

Size : 35, 45, 55, 65, 85

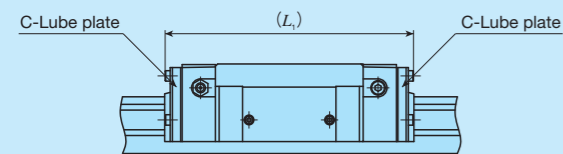

unit : mm

Model number	$L_1$
LRXC 35	103
LRX 35	135
LRXG 35	163
LRXC 45	127
LRX 45	167
LRXG 45	207
LRXC 55	149
LRX 55	197
LRXG 55	251
LRXC 65	198
LRX 65	262
LRXG 65	326
LRX 85	341
LRXG 85	413
LRXL 85	512

Remarks 1 : The values for the slide unit with C-Lube plates at both ends.

2 : The table shows representative model numbers only and is also applicable to all models in the same size.

**Table 12.1 Slide unit with C-Wipers (Supplemental code /RC /RCC)**

Size : 20, 25, 30

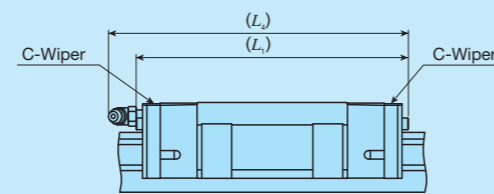

unit : mm

Model number	$L_1$	$L_4$
MXC 20	80	90
MX 20	100	110
MXG 20	120	130
MXL 20	142	153
MXC 25	89	99
MX 25	113	123
MXG 25	128	138
MXL 25	152	162
MXC 30	100	113
MX 30	128	141
MXN 30		138
MXG 30		162
MXNG 30	149	159
MXL 30		190
MXNL 30	177	187

Remarks 1 : The values for the slide unit with C-Wipers at both ends.

2 : The table shows representative model numbers only and is also applicable to all models in the same size.

**Table 12.2 Slide unit with C-Wipers (Supplemental code /RC /RCC)**

Size : 35, 45, 55, 65

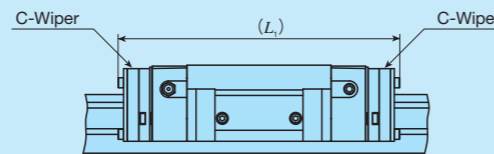

unit : mm

Model number	$L_1$
MXC 35	123
MX 35	155
MXG 35	183
MXL 35	215
MXC 45	149
MX 45	189
MXG 45	229
MXL 45	269
MXC 55	172
MX 55	220
MXG 55	274
MXL 55	328
MXC 65	223
MX 65	287
MXG 65	351
MXL 65	423

Remarks 1 : The values for the slide unit with C-Wipers at both ends.

2 : The table shows representative model numbers only and is also applicable to all models in the same size.

**Table 13.1 Slide unit with double end seals (Supplemental code /V /VV)**

Size : 12, 15, 20, 25, 30

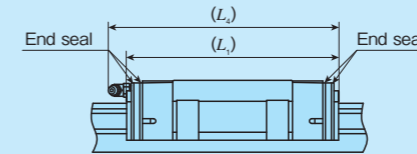

unit : mm

Model number	$L_1$	$L_4$
MXC 12	—	49
—	LRXC 12	44
MX 12	—	58
—	LRX 12	54
MXG 12	—	70
—	LRXG 12	65
MXC 15	LRXC 15	58
MX 15	LRX 15	74
MXG 15	LRXG 15	90
MXC 20	LRXC 20	73
MX 20	LRX 20	93
MXG 20	LRXG 20	113
MXL 20	—	135
MXC 25	LRXC 25	83
MX 25	LRX 25	107
MXG 25	LRXG 25	122
MXL 25	—	146
MXC 30	LRXC 30	93
MX 30	LRX 30	121
MXN 30	—	121
MXG 30	LRXG 30	142
MXNG 30	—	142
MXL 30	—	170
MXNL 30	—	170

Remarks 1 : The values for the slide unit with double end seals at both ends.

2 : The table shows representative model numbers only and is also applicable to all models in the same size.

**Table 13.2 Slide unit with double end seals (Supplemental code /V /VV)**

Size : 35, 45, 55, 65, 85, 100

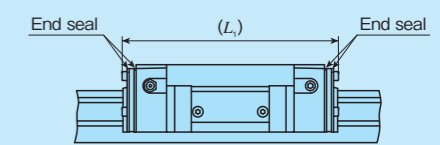

unit : mm

Model number	$L_1$	
MXC 35	LRXC 35	101
MX 35	LRX 35	133
MXG 35	LRXG 35	161
MXL 35	—	193
MXC 45	LRXC 45	127
MX 45	LRX 45	167
MXG 45	LRXG 45	207
MXL 45	—	247
MXC 55	LRXC 55	149
MX 55	LRX 55	197
MXG 55	LRXG 55	251
MXL 55	—	305
MXC 65	—	192
—	LRXC 65	193
MX 65	—	256
—	LRX 65	257
MXG 65	—	320
—	LRXG 65	321
MXL 65	—	392
—	LRX 85	338
—	LRXG 85	410
—	LRXL 85	509
—	LRXG 100	376

Remarks 1 : The values for the slide unit with double end seals at both ends.

2 : The table shows representative model numbers only and is also applicable to all models in the same size.

**Table 14.1 Slide unit with scrapers**  
(Supplemental code /Z, /ZZ)

Size : 12, 15, 20, 25, 30

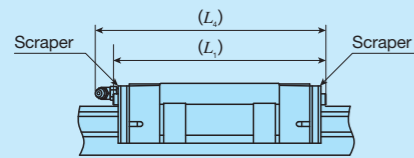

unit : mm

Model number		$L_1$	$L_4$
MXC 12	—	50	53
—	LRXC 12	45	48
MX 12	—	60	63
—	LRX 12	56	58
MXG 12	—	71	74
—	LRXG 12	66	69
MXC 15	LRXC 15	60	61
MX 15	LRX 15	76	77
MXG 15	LRXG 15	92	93
MXC 20	LRXC 20	74	83
MX 20	LRX 20	94	103
MXG 20	LRXG 20	114	123
MXL 20	—	137	146
MXC 25	LRXC 25	85	93
MX 25	LRX 25	109	117
MXG 25	LRXG 25	124	132
MXL 25	—	148	156
MXC 30	LRXC 30	96	107
MX 30	LRX 30	124	135
MXN 30	—	—	132
MXG 30	LRXG 30	145	156
MXNG 30	—	—	153
MXL 30	—	173	184
MXNL 30	—	—	181

Remarks 1 : The values are the slide unit lengths with scrapers at both ends.  
2 : The table shows representative model numbers and is also applicable to all models in the same size.

**Table 14.2 Slide unit with scrapers**  
(Supplemental code /Z, /ZZ)

Size : 35, 45, 55, 65, 85, 100

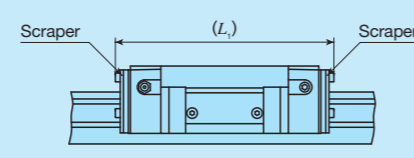

unit : mm

Model number		$L_1$
MXC 35	LRXC 35	103
MX 35	LRX 35	135
MXG 35	LRXG 35	163
MXL 35	—	195
MXC 45	LRXC 45	129
MX 45	LRX 45	169
MXG 45	LRXG 45	209
MXL 45	—	249
MXC 55	LRXC 55	151
MX 55	LRX 55	199
MXG 55	LRXG 55	253
MXL 55	—	307
MXC 65	LRXC 65	194
MX 65	LRX 65	258
MXG 65	LRXG 65	322
MXL 65	—	394
—	LRX 85	339
—	LRXG 85	411
—	LRXL 85	510
—	LRXG 100	378

Remarks 1 : The values are the slide unit lengths with scrapers at both ends.  
2 : The table shows representative model numbers and is also applicable to all models in the same size.

## Lubrication

Lithium-soap base grease (ALVANIA grease EP 2: SHELL) is pre-packed in MX and LRX series slide units. In MX, C-Lube a component part is placed in the ball recirculation path, thereby extending the re-lubrication (greasing) interval time and reducing maintenance work for a long period. MX and LRX series are provided with grease nipple shown in Table 15. Supply nozzles matching the size of grease nipple are also available. For these parts for lubrication, refer to Table 14 and 15.1 on page III-22, and Table 16 on page III-23, and consult **IKO** for further information.

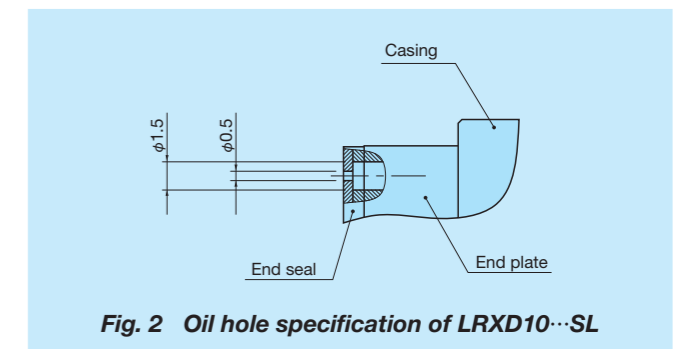

**Fig. 2 Oil hole specification of LRXD10...SL**

**Table 15 Parts for lubrication**

Size	Grease nipple <sup>(1)</sup>	Applicable supply nozzle	Nominal size of female threads for piping
10	Oil hole	Miniature greaser	—
12	A-M3	A-5120V A-5240V	—
15 <sup>(2)</sup>	A-M4	B-5120V B-5240V	M4
20 <sup>(2)</sup>	B-M4	A-8120V	
25 <sup>(2)</sup>		B-8120V	
30 <sup>(3) (4)</sup>	B-M6	Grease gun available on the market	M6
35 <sup>(5)</sup>	JIS type 1		PT1/8
45 <sup>(6)</sup>	JIS type 2		
55			
65			
85	A-PT1/4	PT1/4	
100			

Notes<sup>(1)</sup> : See Table 13.1, 13.2 on Page III-10 for specifications of grease nipples.

<sup>(2)</sup> : The grease nipple type is A-M3 when female threads for bellows (supplemental code of "/J") are specified.

<sup>(3)</sup> : The grease nipple type is A-M4 when female threads for bellows (supplemental code of "/J") are specified.

<sup>(4)</sup> : The grease nipple type of the MXN30 slide unit is B-M4. The grease nipple type is A-M4 when female threads for bellows (supplemental code of "/J") are specified.

<sup>(5)</sup> : The grease nipple mounting screw of the MXN35 slide unit is made smaller along the movement of the slide unit than in the traverse direction. Consult **IKO** when mounting the grease nipple along the movement of the slide unit.

<sup>(6)</sup> : The grease nipple type of the MXN45 slide unit is JIS type 1.

# Dust Protection

MX and LRX series are protected from dust by special rubber seals. But, if large amount of fine contaminants are present, or if large particles of foreign matters such as dust or chips may fall on the track rail, it is recommended to provide protective covers such as bellows for the entire linear motion mechanism. Bellows to match the dimensions of MX and LRX series are optionally available. They are easy to mount and highly effective for dust protection. If required, refer to page III-25 and consult **IKO**. In otherhands, rail cover sheet to cover mounting holes all over the track rail or track rail for mounting from bottom can be prepared also for dust protection. Please consult **IKO** it required.

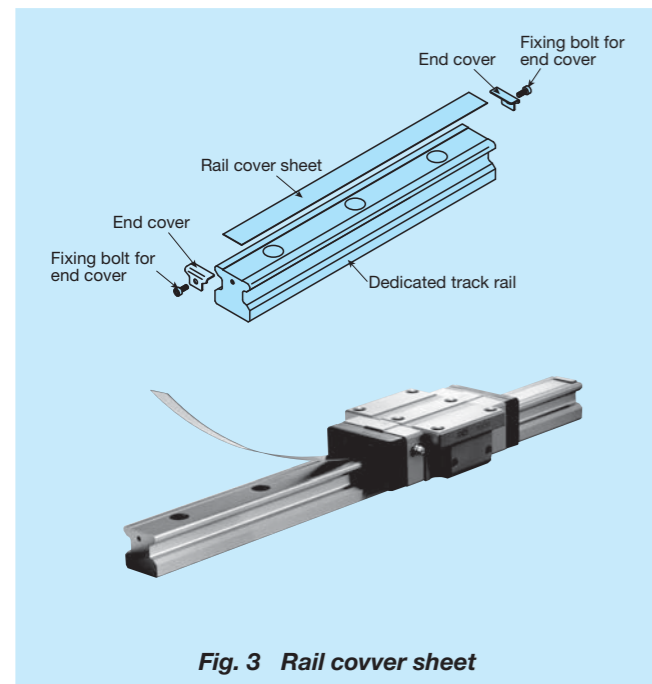

Fig. 3 Rail cover sheet

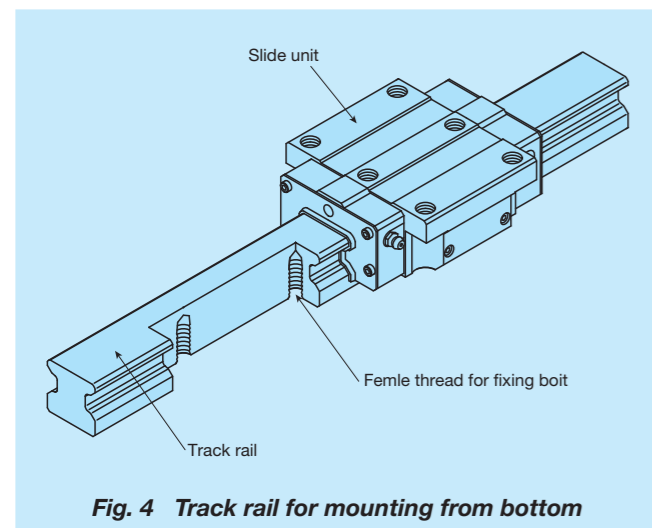

Fig. 4 Track rail for mounting from bottom

# Precautions for Use

**①Mounting surface, reference mounting surface, and general**  
Dedicated bellows are available to MX and LRX series slide units. They are easy to be mounted and have a great dust-proof effect. Consult **IKO** for further information. **IKO** also provide cover tape (see Fig. 5) to cover the mounting holes of the track rail and top-mounted track rails (see Fig. 6) having no mounting holes on their top surfaces. The reference mounting surface of the track rail is on the upper side (in the arrow direction) when the **IKO** mark is normally viewed on the top of the track rail.

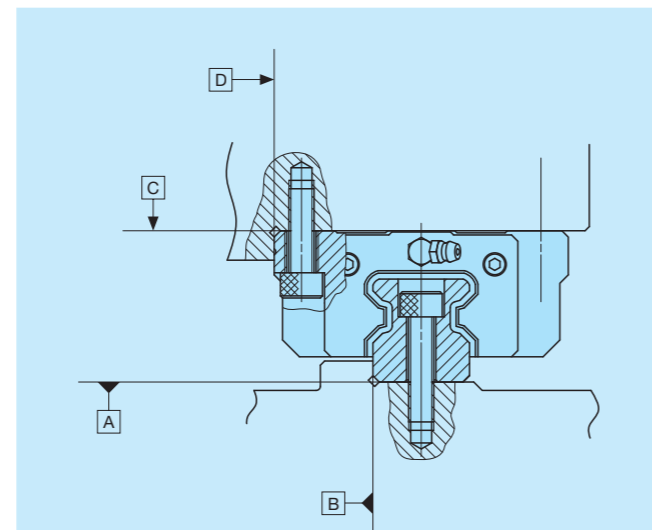

Fig. 5 Reference mounting surfaces and general mounting structure of Linear Way and Linear Roller Way

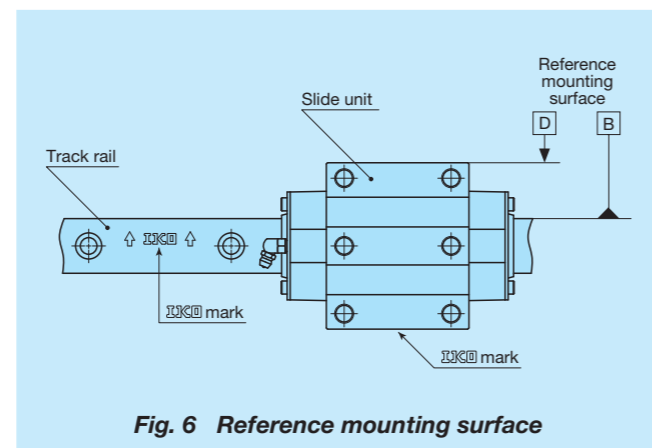

Fig. 6 Reference mounting surface

## ②Mounting slide unit

In the slide unit, mounting holes are also prepared on the middle of slide unit (see Table 16.1 and 16.2) to support any direction of load and moment in good balance. It is recommended to fix all mounting holes to have full performance of products. For mounting slide unit of Compact block type and Low section block type, insertion depth shown in Table 16.1 and 16.2 is recommended to keep certain fixing strength. Similarly, the penetration depth of the mounting holes in the center of the slide unit width should be equal to or less than the maximum penetration depth in the Table.

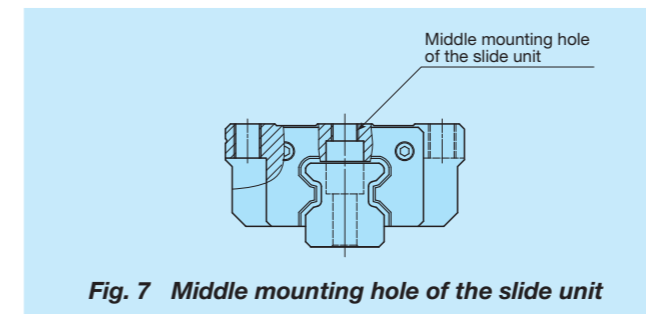

Fig. 7 Middle mounting hole of the slide unit

Table 16.1 Screwing depth of slide unit mounting holes for Compact block type

Model number		Recommended minimum depth
MXS 15	LRXS 15	4.5
MXS 20	LRXS 20	5.5
MXS 25	LRXS 25	7
MXS 30	LRXS 30	9

Remark : The table shows representative model numbers and is also applicable to all models in the same size.

Table 16.2 Screwing depth of slide unit mounting holes for Low section block type

Model number		Recommended minimum depth
MXNS 30		8
MXNS 35		8.5
MXNS 45		10.5
MXNS 55		14

Remark : The table shows representative model numbers and is also applicable to all models in the same size of low section block type.

## ③Corner radius and shoulder height of reference mounting surfaces

It is recommended to make a relieved fillet at the corner of the mating reference mounting surfaces as shown in Fig. 8. Otherwise, corner radius  $R$  is recommended shown in Table 17. Table 17 shows recommended shoulder heights and radius of the reference mounting surfaces.

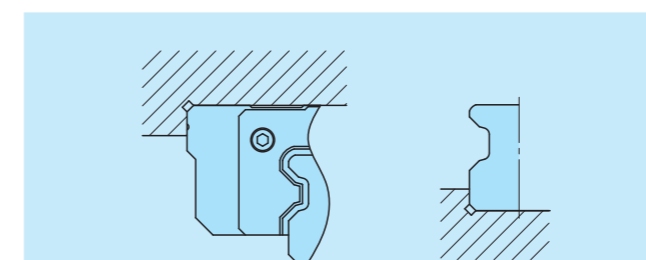

Fig. 8 Relieved radius shape of reference mounting surface

Table 17 Corner radius and shoulder height of reference mounting surfaces

unit : mm			
Size	Slide unit Shoulder height $h_1$	Track rail Shoulder height $h_2$	Relieved radius $R$ (max.)
10	4	1	0.3
12	4	2	0.5
15	4	3	0.5
20	5	4	0.5
25	6	5	1
30	8	5.5	1
35	8	5.5	1
45	8	7	1.5
55	10	8	1.5
65	10	10	1.5
85	14	14	2.5 (Slide unit)
			1.5 (Track rail)
100	14	13	2.5

## ④Tightening torque of mounting bolts

The standard torque values for MX and LRX series mounting bolts are shown in Tables 18. When machines or equipment are subjected to severe vibration, shock, large fluctuating load, or moment load, the bolts should be tightened with a torque 1.2 to 1.5 times higher than the standard torque values shown. When the mating member material is cast iron or aluminum, tightening torque should be lowered in accordance with the strength characteristics of the material.

Table 18 Tightening torque of mounting bolts

Bolt size	Tightening torque N·m	
	Carbon steel bolt	Stainless steel bolt
M 2.6×0.45	—	0.70
M 3 ×0.5	1.7	1.1
M 4 ×0.7	4.0	2.5
M 5 ×0.8	7.9	5.0
M 6 ×1	13.3	8.5
M 8 ×1.25	32.0	20.4
M10 ×1.5	62.7	—
M12 ×1.75	108	—
M14 ×2	172	—
M16 ×2	263	—
M20 ×2.5	512	—
M24 ×3	882	—
M30 ×3.5	1 750	—

Remarks 1 : The recommended tightening torque is for strength division 12.9 or property division A2-70.

2 : For the flange type slide units (MXC, MX, MXG, MXL, LRXC, LRX, and LRXG) of Sizes 15, 20, 25, 30, and 35, recommended tightening torques of mounting screws in the center mounting holes are 70 to 80% of the values in the Table.

# IKO C-Lube Linear Roller Way Super MX

Flange type mounting from top/bottom

Shape	MX • LRX				
Size	12	15	20	25	30
	35	45	55	65	85

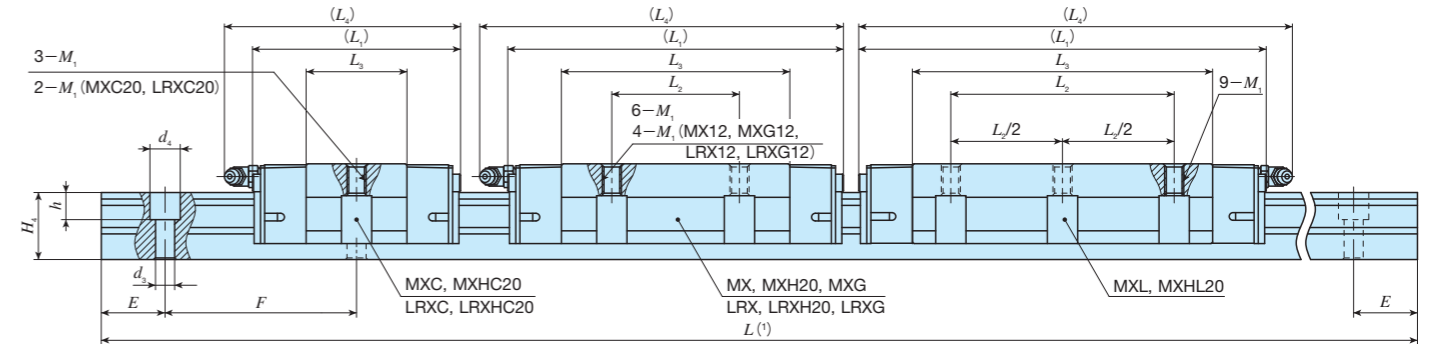
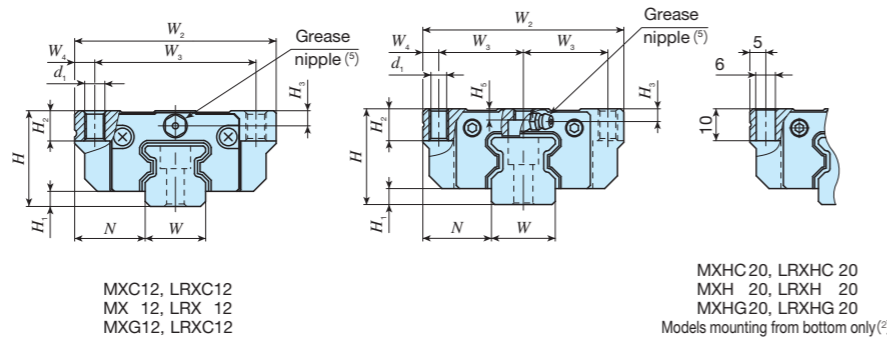

Model number	Interchangeable	Mass (Ref.)		Dimensions of assembly mm			Dimensions of slide unit mm										Dimensions of track rail mm						Mounting bolt for track rail <sup>(3)</sup>	Basic dynamic load rating <sup>(4)</sup>	Basic static load rating <sup>(4)</sup>	Static moment rating <sup>(4)</sup>						
		Slide unit kg	Track rail kg/m	H	H <sub>1</sub>	N	W <sub>2</sub>	W <sub>3</sub>	W <sub>4</sub>	L <sub>1</sub>	L <sub>2</sub>	L <sub>3</sub>	L <sub>4</sub>	d <sub>1</sub>	M <sub>1</sub>	H <sub>2</sub>	H <sub>3</sub>	H <sub>5</sub>	W	H <sub>4</sub>	d <sub>3</sub>	d <sub>4</sub>				h	E	F	Bolt size×length	C	C <sub>0</sub>	T <sub>0</sub>
MXC 12	○	0.058								40	-	15.8	44															4 250	6 500	49.4	18.6	18.6
LRXC 12	○									37		14.8	40															3 900	6 090	46.3	16.3	16.3
MX 12	○	0.092	0.92	19	3	14	40	32	4	50		25.4	53	3.4	M4	6	3	-	12	12	3.5	6	4.5	20	40	M3×12	6 120	10 400	79.1	45.8	45.8	
LRX 12	○									47	15	25.3	50														5 890		78.7	45.2	45.2	
MXG 12	○	0.13								61		36.6	64														8 120	15 000	114	92.7	92.7	
LRXG 12	○									58		35.8	61														7 710	14 600	111	88.6	88.6	
MXC 15	○	0.13								52	-	24	55														7 730	12 000	113	50.6	50.6	
LRXC 15	○									68		40	71	4.4	M5	7	3.5	3	15	16.5	4.5	8	6	30	60	M4×16	11 500	20 000	188	136	136	
MX 15	○	0.20	1.65	24	4	16	47	19	4.5	84	30	56	87													14 900	28 000	263	262	262		
LRX 15	○									84		56	87														16 100	26 400	341	150	150	
MXG 15	○	0.28								86		51.6	94														23 400	42 700	550	379	379	
LRXG 15	○									106	40	71.6	114														30 100	58 900	760	713	713	
MXC 20 <sup>(2)</sup>	○	0.29								128	70	94.1	137														37 200	77 200	996	1 210	1 210	
LRXC 20 <sup>(2)</sup>	○																															
MX 20 <sup>(2)</sup>	○	0.44	2.73	30	5	21.5	63	26.5	5																		16 100	26 400	341	150	150	
LRX 20 <sup>(2)</sup>	○																										23 400	42 700	550	379	379	
MXG 20 <sup>(2)</sup>	○	0.61																									30 100	58 900	760	713	713	
LRXG 20 <sup>(2)</sup>	○																										37 200	77 200	996	1 210	1 210	
MXL 20 <sup>(2)</sup>	-	0.80																														
LRXL 20 <sup>(2)</sup>	-																															

Notes<sup>(1)</sup> : Track rail lengths are shown in Table 2.1 on page II-153 and Table 2.3 on page II-154.  
<sup>(2)</sup> : They can be mounted from top side only.  
 For mounting from bottom side, MXHC20, MXH20, MXHG20, MXHL20, LFXHC20, LFXH20 and LFXHG20 can be used.  
<sup>(3)</sup> : The appended track rail mounting bolts are hexagon socket head bolts of JIS B 1176 or equivalent. In assembled set of MX series, track rail mounting bolt is not appended.  
<sup>(4)</sup> : The directions of basic dynamic load rating (C), basic static load rating (C<sub>0</sub>) and static moment rating (T<sub>0</sub>, T<sub>x</sub>, T<sub>y</sub>) are shown in the sketches below. The upper values in the T<sub>x</sub> and T<sub>y</sub> columns apply to one slide unit, and the lower values apply to two slide units in close contact.  
<sup>(5)</sup> : For grease nipple specifications, see Table 15 on page II-166.  
 Remark : A mounting thread hole for grease nipple is provided on the left and right end plates respectively.

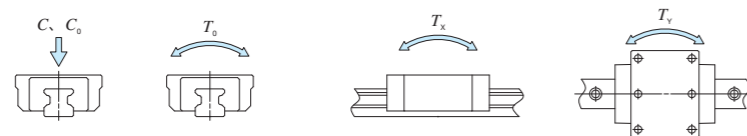

**Example of identification number of assembled set**

Model code	Size	Part code	Preload symbol	Class symbol	Interchangeable code	Supplemental code
<b>MX</b>	<b>G</b>	<b>15</b>	<b>C2</b>	<b>R360</b>	<b>T1</b>	<b>P</b>
<b>S1</b>	<b>/F</b>					

① Series: MX (Flange type mounting from top/bottom), LRX

② Length of slide unit: C (Short), No symbol (Standard), G (High rigidity long), L (Extra high rigidity long)

③ Size: 12, 15, 20

④ Number of slide unit (two units)

⑤ Length of track rail (360mm)

⑥ Preload amount: No symbol (Standard), T1 (Light preload), T2 (Medium preload), T3 (Heavy preload)

⑦ Accuracy class: H (High), P (Precision), SP (Super precision), UP (Ultra precision)

⑧ Interchangeable code: S1 (Interchangeable specification), S2 (Interchangeable specification), No symbol (Non interchangeable specification)

⑨ Special specification: A, D, E, F, GE, HP, I, J, L, LF, MA, MN, N, Q, RC, T, UR, V, W, Y, Z



# IKO C-Lube Linear Roller Way Super MX

Flange type mounting from top/bottom

Shape	MX • LRX				
Size	12	15	20	25	30
	35	45	55	65	85

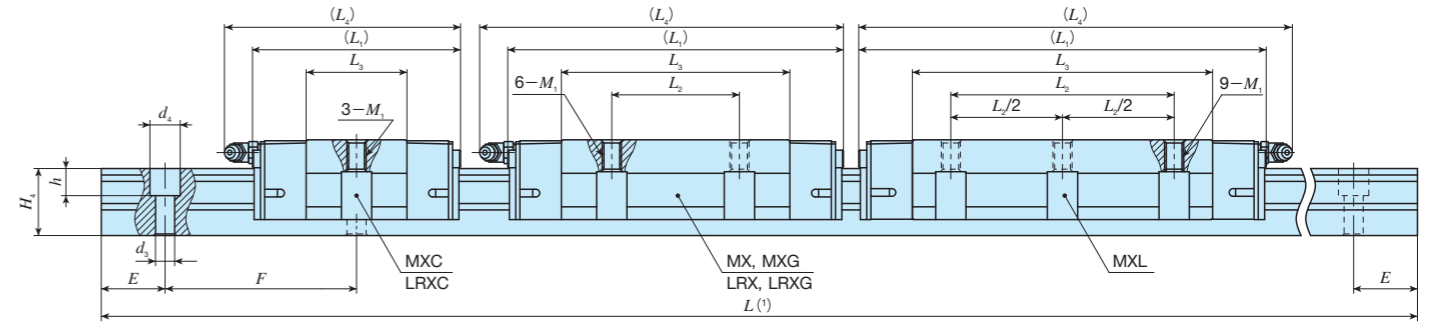
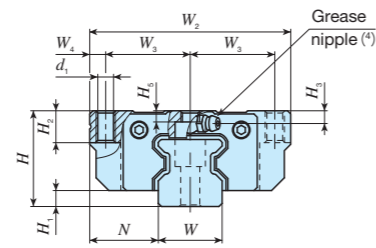

Model number	Interchangeable	Mass (Ref.)		Dimensions of assembly mm			Dimensions of slide unit mm							Dimensions of track rail mm						Mounting bolt for track rail (2)	Basic dynamic load rating (3)	Basic static load rating (3)	Static moment rating (3)									
		Slide unit kg	Track rail kg/m	H	H1	N	W2	W3	W4	L1	L2	L3	L4	d1	M1	H2	H3	H5	W				H4	d3	d4	h	E	F	Bolt size×length	C N	C0 N	T0 N·m
MXC 25	LRXC 25	○	0.44	3.59	36	6	23.5	70	28.5	6.5	74	—	36	83	7	M 8	10	5	5	23	24.5	7	11	9	30	60	M6×25	21 600	33 800	500	213 1 810	213 1 810
MX 25	LRX 25	○	0.67								98	45	60	107														573 573	3 800 3 800			
MXG 25	LRXG 25	○	0.84								113	70	75	122														885 5 380	1 040 5 380			
MXL 25	—	—	1.08								137	70	99	146														1 530 8 480	1 370 8 480			
MXC 30	LRXC 30	○	0.78	5.01	42	6.5	31	90	36	9	85	—	42.4	95	8.5	M10	10	6.5	5.5	28	28	9	14	12	40	80	M8×28	29 200	44 600	808	329 2 740	329 2 740
MX 30	LRX 30	○	1.20								113	52	70.4	123														883 5 780	1 350 5 780			
MXG 30	LRXG 30	○	1.58								134	80	91.4	144														1 470 8 740	1 750 8 740			
MXL 30	—	—	2.03								162	80	119.4	172														2 500 13 600	2 290 13 600			

Notes (1) : Track rail lengths are shown in Table 2.1 on page II-153 and Table 2.3 on page II-154.  
 (2) : The appended track rail mounting bolts are hexagon socket head bolts of JIS B 1176 or equivalent. In assembled set of MX series, track rail mounting bolt is not appended.  
 (3) : The directions of basic dynamic load rating (C), basic static load rating (C0) and static moment rating (T0, Tx, Ty) are shown in the sketches below. The upper values in the Tx and Ty columns apply to one slide unit, and the lower values apply to two slide units in close contact.  
 (4) : For grease nipple specifications, see Table 15 on page II-166.  
 Remark : A mounting thread hole for grease nipple is provided on the left and right end plates respectively.

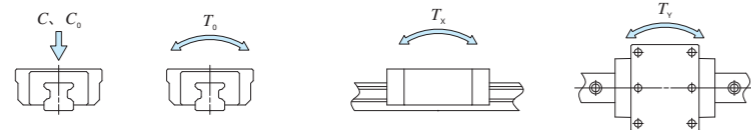

### Example of identification number of assembled set

Model code	Size	Part code	Preload symbol	Class symbol	Interchangeable code	Supplemental code		
<b>MX</b>	<b>G</b>	<b>25</b>	<b>C2</b>	<b>R840</b>	<b>T1</b>	<b>P</b>	<b>S1</b>	<b>/F</b>
1	2	3	4	5	6	7	8	9

<b>① Series</b> MX Flange type mounting from top/bottom LRX	<b>② Length of slide unit</b> C Short No symbol Standard G High rigidity long L Extra high rigidity long	<b>③ Size</b> 25, 30	<b>④ Number of slide unit (two units)</b>	<b>⑤ Length of track rail (840mm)</b>	<b>⑥ Preload amount</b> No symbol Standard T1 Light preload T2 Medium preload T3 Heavy preload	<b>⑦ Accuracy class</b> H High P Precision SP Super precision UP Ultra precision	<b>⑧ Interchangeable code</b> S1 Interchangeable specification S2 Interchangeable specification No symbol Non interchangeable specification	<b>⑨ Special specification</b> A, D, E, F, GE, HP, I, J, L, LF MA, MN, N, O, RC, T, UR, V W, Y, Z
---	--	-------------------------	---	---------------------------------------	--	--	--	--

# IKO C-Lube Linear Roller Way Super MX

Flange type mounting from top/bottom

Shape	MX • LRX				
Size	12	15	20	25	30
	35	45	55	65	100

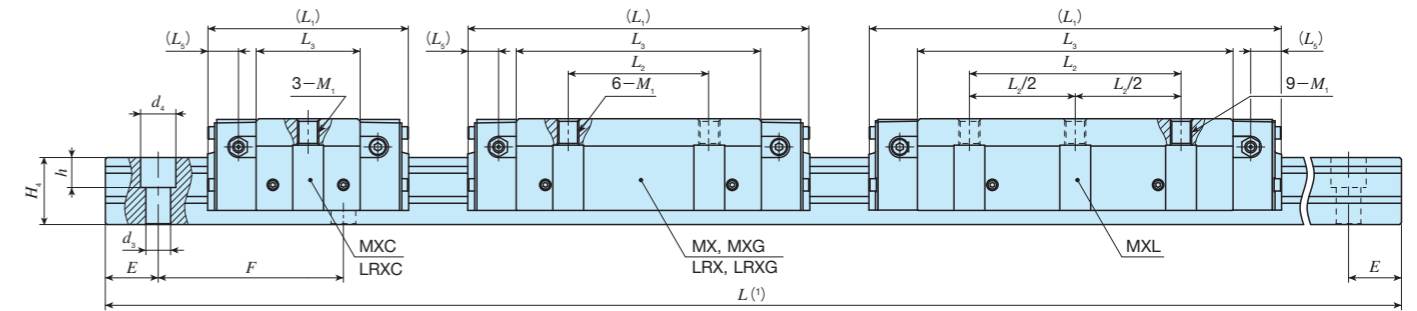
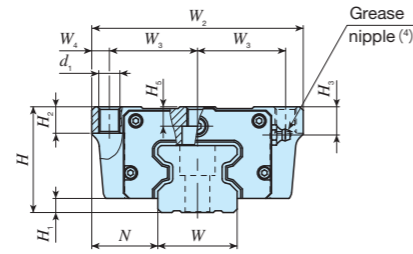

Model number	Interchangeable	Mass (Ref.)		Dimensions of assembly mm			Dimensions of slide unit mm							Dimensions of track rail mm						Mounting bolt for track rail (2)	Basic dynamic load rating (3)	Basic static load rating (3)	Static moment rating (3)								
		Slide unit kg	Track rail kg/m	H	H <sub>1</sub>	N	W <sub>2</sub>	W <sub>3</sub>	W <sub>4</sub>	L <sub>1</sub>	L <sub>2</sub>	L <sub>3</sub>	L <sub>5</sub>	d <sub>1</sub>	M <sub>1</sub>	H <sub>2</sub>	H <sub>3</sub>	H <sub>5</sub>	W				H <sub>4</sub>	d <sub>3</sub>	d <sub>4</sub>	h	E	F	Bolt size×length	C N	C <sub>0</sub> N
MXC 35	○	1.13	6.88	48	6.5	33	100	41	9	92	—	46.6	12.7	8.5	M10	13	13	7	34	32	9	14	12	40	80	M 8×35	39 500	60 000	1 300	506	506
LRXC 35	○	12.5								12.5	12.5	12.5	13 360														13 360				
MX 35	○	1.76								124	62	78.6	1 360														1 360				
LRX 35	○	12.5								106.6	2 170	2 170																			
MXG 35	○	2.41	152	106.6	2 930	2 440	2 440																								
LRXG 35	○	12.5	184	100	138.6	13 800	13 800																								
MXL 35	—	3.00	90 800	175 000	3 800	4 060	4 060																								
MXC 45	○	2.11	10.8	60	8	37.5	120	50	10	114	—	59	17.5	10.5	M12	15	16	11	45	38	14	20	17	52.5	105	M12×40	64 100	95 600	2 660	1 010	1 010
LRXC 45	○	12.7								12.7	12.7	12.7															1 010			1 010	
MX 45	○	3.26								154	80	99															2 700			2 700	
LRX 45	○	12.7								139	4 430	4 430																			
MXG 45	○	4.60	194	139	6 200	5 220	5 220																								
LRXG 45	○	12.7	234	120	179	29 000	29 000																								
MXL 45	—	5.66	151 000	287 000	7 980	8 560	8 560																								

Notes (1) : Track rail lengths are shown in Table 2.1 on page II-153 and Table 2.3 on page II-154.  
 (2) : The appended track rail mounting bolts are hexagon socket head bolts of JIS B 1176 or equivalent. In assembled set of MX series, track rail mounting bolt is not appended.  
 (3) : The directions of basic dynamic load rating (C), basic static load rating (C<sub>0</sub>) and static moment rating (T<sub>0</sub>, T<sub>x</sub>, T<sub>y</sub>) are shown in the sketches below. The upper values in the T<sub>x</sub> and T<sub>y</sub> columns apply to one slide unit, and the lower values apply to two slide units in close contact.  
 (4) : For grease nipple specifications, see Table 15 on page II-166.  
 Remark : Three female threaded holes for grease nipple are prepared on each end plate.

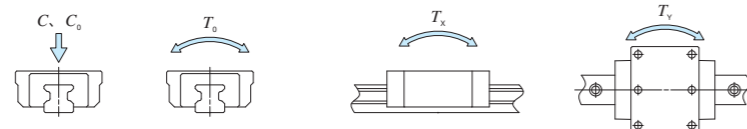

### Example of identification number of assembled set

Model code	Size	Part code	Preload symbol	Class symbol	Interchangeable code	Supplemental code
<b>MX</b>	<b>G</b>	<b>35</b>	<b>C2</b>	<b>R1200</b>	<b>T2</b>	<b>P</b>
<b>S1</b>	<b>/F</b>					

① Series MX Flange type mounting from top/bottom LRX	② Length of slide unit C Short No symbol Standard G High rigidity long L Extra high rigidity long	③ Size 35, 45	④ Number of slide unit (two units)	⑤ Length of track rail (120mm)	⑥ Preload amount No symbol Standard T <sub>1</sub> Light preload T <sub>2</sub> Medium preload T <sub>3</sub> Heavy preload	⑦ Accuracy class H High P Precision SP Super precision UP Ultra precision	⑧ Interchangeable code S1 Interchangeable specification S2 Interchangeable specification No symbol Non interchangeable specification	⑨ Special specification A, D, E, F, GE, HP, I, J, L, LF, MA, MN, N, PS, Q, RC, T, UR, V, W, Y, Z
--	---	------------------	------------------------------------	--------------------------------	---	---	---	---

# IKO C-Lube Linear Roller Way Super MX

Flange type mounting from top/bottom

Shape	MX • LRX				
Size	12	15	20	25	30
	35	45	55	65	85

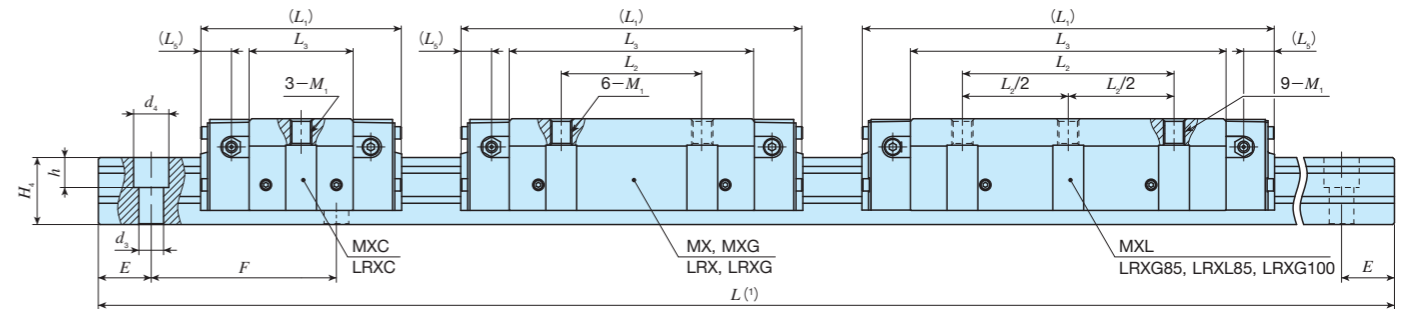
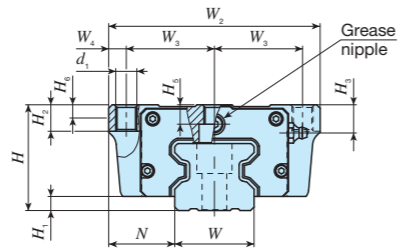

Model number	Interchangeable	Mass (Ref.)		Dimensions of assembly mm			Dimensions of slide unit mm							Dimensions of track rail mm						Mounting bolt for track rail <sup>(2)</sup>	Basic dynamic load rating <sup>(3)</sup>	Basic static load rating <sup>(3)</sup>	Static moment rating <sup>(3)</sup>										
		Slide unit kg	Track rail kg/m	H	H <sub>1</sub>	N	W <sub>2</sub>	W <sub>3</sub>	W <sub>4</sub>	L <sub>1</sub>	L <sub>2</sub>	L <sub>3</sub>	L <sub>5</sub>	d <sub>1</sub>	M <sub>1</sub>	H <sub>2</sub>	H <sub>3</sub>	H <sub>5</sub>	H <sub>6</sub>				W	H <sub>4</sub>	d <sub>3</sub>	d <sub>4</sub>	h	E	F	Bolt size×length	C	C <sub>0</sub>	T <sub>0</sub>
MXC 55	LRXC 55	○	3.49	14.1	70	9	43.5	140	58	12	136	—	72	20	12.5	M14	17	16	14	—	53	43	16	23	20	60	120	M14×45	99 700	149 000	4 830	1 880	1 880
MX 55	LRX 55	○	5.42								184	95	120																5 040	5 040			
MXG 55	LRXG 55	○	7.93								238	150	174																10 400	10 400			
MXL 55	—	—	10.1								292	200	228																17 700	17 700			
MXC 65	LRXC 65	○	7.18	22.6	90	12	53.5	170	71	14	180	—	95	26.3	14.5	M16	23	18	18.5	—	63	56	18	26	22	75	150	M16×60	174 000	249 000	9 790	4 200	4 200
MX 65	LRX 65	○	11.5								181	110	159	32 000															32 000				
MXG 65	LRXG 65	○	16.0								244	200	223	4 200															4 200				
MXL 65	—	—	20.8								245	250	26.6	11 300															11 300				
—	LRX 85	—	25.4	36.7	110	16	65	215	92.5	15	323	140	232	27.5	17.8	M20	35	22	25.5	20	85	67	26.5	39	30	90	180	M24×70	440 000	753 000	38 900	29 500	29 500
—	LRXG 85	—	32.7								395	200	304																163 000	163 000			
—	LRXL 85	—	44.0								494	280	403																50 000	50 000			
—	LRXG 100*	—	43.0								43.2	120	15																75	250	110	15	362

Notes<sup>(1)</sup> : Track rail lengths are shown in Table 2.1 on page II-153 and Table 2.3 on page II-154.  
<sup>(2)</sup> : The appended track rail mounting bolts are hexagon socket head bolts of JIS B 1176 or equivalent. In assembled set of MX series, track rail mounting bolt is not appended.  
<sup>(3)</sup> : The directions of basic dynamic load rating (C), basic static load rating (C<sub>0</sub>) and static moment rating (T<sub>0</sub>, T<sub>x</sub>, T<sub>y</sub>) are shown in the sketches below. The upper values in the T<sub>x</sub> and T<sub>y</sub> columns apply to one slide unit, and the lower values apply to two slide units in close contact.

Remarks 1 : For grease nipple specifications, see Table 15 on page II-166.  
 2 : Three female threaded holes for grease nipple are prepared on each end plate.  
 3 : Model number marked \* is semi-standard item.

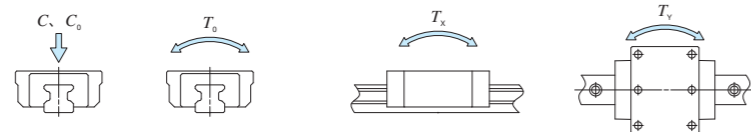

### Example of identification number of assembled set

Model code	Size	Part code	Preload symbol	Class symbol	Interchangeable code	Supplemental code
<b>MX</b>	<b>G</b>	<b>55</b>	<b>C2</b>	<b>R3000</b>	<b>T2</b>	<b>P</b>
<b>S1</b>	<b>/F</b>					

① Series	② Length of slide unit	③ Size	④ Number of slide unit (two units)	⑤ Preload amount	⑥ Length of track rail (3000mm)	⑦ Interchangeable code	⑧ Accuracy class	⑨ Special specification
MX LRX	C No symbol G L	35, 45, 55, 65, 85, 100	2	No symbol T <sub>1</sub> T <sub>2</sub> T <sub>3</sub>	70	S1 S2 No symbol	H P SP UP	A, D, E, F, GE, HP, I, J, L, LF MA, MN, PS, Q, RC, T, UR, V W, Y, Z

# IKO C-Lube Linear Roller Way Super MX

## Block type mounting from top

Shape	MXD • LRXD				
Size	10	12	15	20	25
	30	35	45	55	65

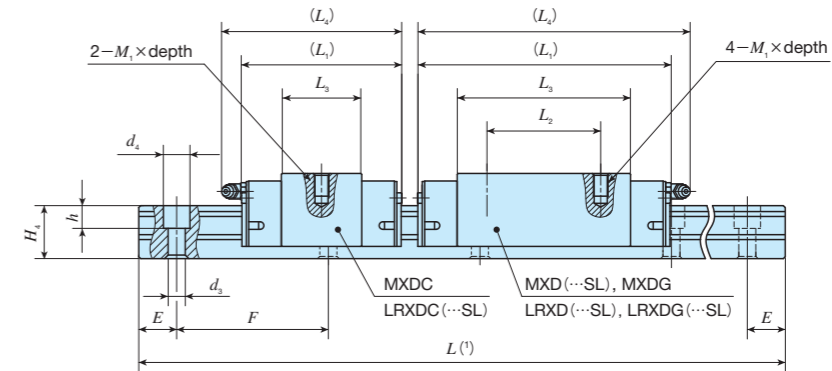
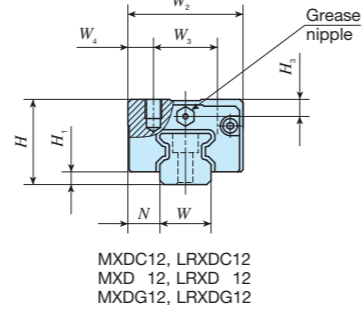
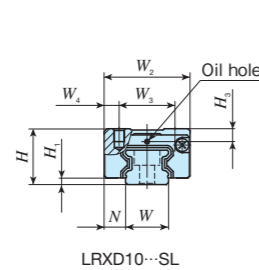

Model number	MX	LRX (Non C-Lube)	Interchangeable	Mass (Ref.)		Dimensions of assembly mm			Dimensions of slide unit mm						Dimensions of track rail mm						Mounting bolt for track rail (2)	Basic dynamic load rating (3)	Basic static load rating (3)	Static moment rating (3)						
				Slide unit kg	Track rail kg/m	H	H <sub>1</sub>	N	W <sub>2</sub>	W <sub>3</sub>	W <sub>4</sub>	L <sub>1</sub>	L <sub>2</sub>	L <sub>3</sub>	L <sub>4</sub>	M <sub>1</sub> × depth	H <sub>3</sub>	W	H <sub>4</sub>	d <sub>3</sub>				d <sub>4</sub>	h	E	F	Bolt size × length	C	C <sub>0</sub>
—	—	LRXD 10...SL	—	0.028	0.48	13	1.5	5	20	13	3.5	34.5	12	20.8	—	M2.6 × 3	3	10	8	3.5	6	3.5	12.5	25	M3 × 10	3 200	5 880	37.9	20.9 140	20.9 140
MXDC 12	—	LRXDC 12	○	0.045	—	—	—	—	—	—	—	40	—	15.8	44	M4 × 4.5	4	12	12	3.5	6	4.5	20	40	M3 × 12	4 250	6 500	49.4	18.6 196	18.6 196
—	—	LRXDC 12...SL	○									37	—	14.8	40											—	—	—	—	—
MXD 12	—	LRXD 12	○	0.072	0.92	20	3	7.5	27	15	6	50	—	25.4	53	M4 × 4.5	4	12	12	3.5	6	4.5	20	40	M3 × 12	6 120	10 400	79.1	45.8 371	45.8 371
MXD 12...SL	—	LRXD 12...SL	○									47	—	25.3	50											—		—	—	—
MXDG 12	—	LRXDG 12	○	0.097	—	—	—	—	—	—	—	61	—	36.6	64	M4 × 4.5	4	12	12	3.5	6	4.5	20	40	M3 × 12	8 120	15 000	114	92.7 628	92.7 628
—	—	LRXDG 12...SL	○									58	—	35.8	61											—	—	—	—	—

Notes (1) : Track rail lengths are shown in Table 2.1 and Table 2.2 on page II-153, and Table 2.3 and Table 2.4 on page II-154.

(2) : The appended track rail mounting bolts are hexagon socket head bolts of JIS B 1176 or equivalent. In stainless steel model, stainless steel bolts are appended. In assembled set of MX series, track rail mounting bolt is not appended.

(3) : The directions of basic dynamic load rating (C), basic static load rating (C<sub>0</sub>) and static moment rating (T<sub>0</sub>, T<sub>x</sub>, T<sub>y</sub>) are shown in the sketches below. The upper values in the T<sub>x</sub> and T<sub>y</sub> columns apply to one slide unit, and the lower values apply to two slide units in close contact.

Remarks 1 : Size 10 is provided with oil holes. For specification, see Fig. 2 on page II-166.

2 : For grease nipple specifications, see Table 15 on page II-166.

3 : In size 12, mounting thread hole for grease nipple is provided on the left and right end plates respectively.

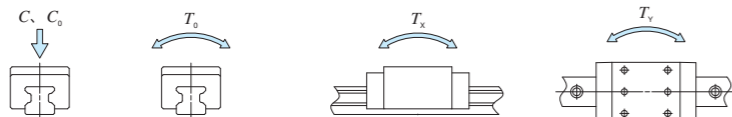

### Example of identification number of assembled set

Model code	Size	Part code	Material symbol	Preload symbol	Class symbol	Interchangeable code	Supplemental code		
<b>MXD</b>	<b>G</b>	<b>12</b>	<b>C2</b>	<b>R560</b>	<b>T1</b>	<b>P</b>	<b>S1</b>	<b>/F</b>	
1	2	3	4	5	6	7	8	9	10

<b>① Series</b> MXD Block type mounting from bottom LRXD	<b>④ Number of slide unit (two units)</b> 2	<b>⑦ Preload amount</b> No symbol Standard T1 Light preload T2 Medium preload T3 Heavy preload	<b>⑩ Interchangeable code</b> S1 Interchangeable specification S2 Interchangeable specification No symbol Non interchangeable specification
<b>② Length of slide unit</b> C Short No symbol Standard G High rigidity long	<b>⑤ Length of track rail (560mm)</b> 560	<b>⑧ Accuracy class</b> H High P Precision SP Super precision UP Ultra precision	<b>⑨ Special specification</b> A, D, E, F, HP, I, L, LF, MA MN, N, Q, T, V, W, Y, Z
<b>③ Size</b> 10, 12	<b>⑥ Material symbol</b> No symbol High carbon steel SL Stainless steel		



# IKO C-Lube Linear Roller Way Super MX

## Block type mounting from top

Shape	MXD • LRXD				
Size	10	12	15	20	25
	30	35	45	55	65

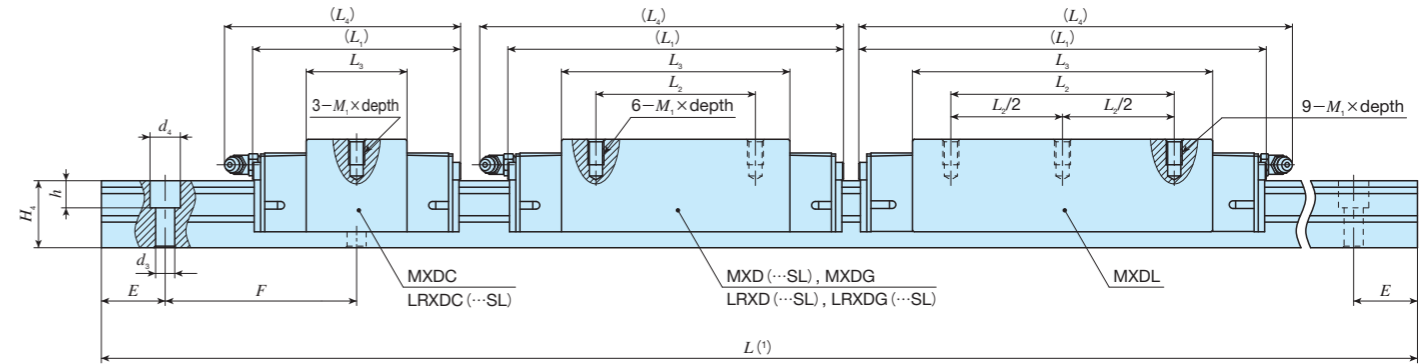
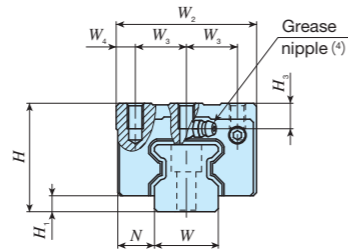

Model number	LRX (Non C-Lube)	Interchangeable	Mass (Ref.)		Dimensions of assembly mm			Dimensions of slide unit mm							Dimensions of track rail mm						Mounting bolt for track rail (2)	Basic dynamic load rating (3)	Basic static load rating (3)	Static moment rating (3)					
			Slide unit kg	Track rail kg/m	H	H1	N	W2	W3	W4	L1	L2	L3	L4	M1 x depth	H3	W	H4	d3	d4				h	E	F	Bolt size x length	C N	C0 N
MXDC 15	LRXDC 15	○	0.13	1.65	28	4	9.5	34	13	4	52	-	24	55	M4 x 8	7.5	15	16.5	4.5	8	6	30	60	M4 x 16	7 730	12 000	113	50.6 457	50.6 457
-	LRXDC 15-SL	○									68	26	40	71															
MXD 15	LRXD 15	○	0.19	1.65	28	4	9.5	34	13	4	68	26	40	71	M4 x 8	7.5	15	16.5	4.5	8	6	30	60	M4 x 16	11 500	20 000	188	136 942	136 942
MXD 15-SL	LRXD 15-SL	○									84	56	87																
MXDG 15	LRXDG 15	○	0.26	1.65	28	4	9.5	34	13	4	84	56	87	M4 x 8	7.5	15	16.5	4.5	8	6	30	60	M4 x 16	14 900	28 000	263	262 1 590	262 1 590	
-	LRXDG 15-SL	○																											
MXDC 20	LRXDC 20	○	0.25	2.73	34	5	12	44	16	6	66	-	31.6	74	M5 x 8	8	20	21	6	9.5	8.5	30	60	M5 x 20	16 100	26 400	341	150 1 260	150 1 260
-	LRXDC 20-SL	○									86	36	51.6	94															
MXD 20	LRXD 20	○	0.38	2.73	34	5	12	44	16	6	86	36	51.6	94	M5 x 8	8	20	21	6	9.5	8.5	30	60	M5 x 20	23 400	42 700	550	379 2 520	379 2 520
MXD 20-SL	LRXD 20-SL	○									106	50	71.6	114															
MXDG 20	LRXDG 20	○	0.52	2.73	34	5	12	44	16	6	106	50	71.6	114	M5 x 8	8	20	21	6	9.5	8.5	30	60	M5 x 20	30 100	58 900	760	713 4 200	713 4 200
-	LRXDG 20-SL	○																											
MXDL 20	-	-	0.67	-	34	5	12	44	16	6	128	70	94.1	137	M5 x 8	8	20	21	6	9.5	8.5	30	60	M5 x 20	37 200	77 200	996	1 210 6 560	1 210 6 560

Notes (1) : Track rail lengths are shown in Table 2.1 and Table 2.2 on page II-153 and Table 2.3 and Table 2.4 on page II-154.  
 (2) : The appended track rail mounting bolts are hexagon socket head bolts of JIS B 1176 or equivalent. In stainless steel model, stainless steel bolts are appended. In assembled set of MX series, track rail mounting bolt is not appended.  
 (3) : The directions of basic dynamic load rating (C), basic static load rating (C0) and static moment rating (T0, Tx, Ty) are shown in the sketches below. The upper values in the Tx and Ty columns apply to one slide unit, and the lower values apply to two slide units in close contact.  
 (4) : For grease nipple specifications, see Table 15 on page II-166.  
 Remark : A mounting thread hole for grease nipple is provided on the left and right end plates respectively.

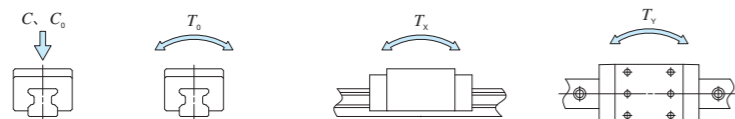

### Example of identification number of assembled set

Model code	Size	Part code	Material symbol	Preload symbol	Class symbol	Interchangeable code	Supplemental code
MXD	G	20	C2	R840	T1	P	S1 / F
1	2	3	4	5	6	7	8

<b>1 Series</b> MXD Block type mounting from bottom LRXD	<b>2 Length of slide unit</b> C Short No symbol Standard G High rigidity long L Extra high rigidity long	<b>3 Size</b> 15, 20	<b>4 Number of slide unit (two units)</b> 2, 3, 4, 5, 6, 7, 8, 9, 10	<b>5 Length of track rail (840mm)</b> R840	<b>6 Material symbol</b> No symbol High Carbon steel SL Stainless steel	<b>7 Preload amount</b> No symbol Standard T1 Light preload T2 Medium preload T3 Heavy preload	<b>8 Accuracy class</b> H High P Precision SP Super precision UP Ultra precision	<b>9 Interchangeable code</b> S1 Interchangeable specification S2 Interchangeable specification No symbol Non interchangeable specification	<b>10 Special specification</b> A, D, E, F, HP, I, J, L, LF, MA, MN, N, Q, RC, T, UR, V, W, Y, Z
--	--	-------------------------	---	---	---	--	--	--	---

# IKO C-Lube Linear Roller Way Super MX

## Block type mounting from top

MXD • LRXD

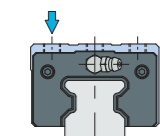

Size	10	12	15	20	25
	30	35	45	55	65

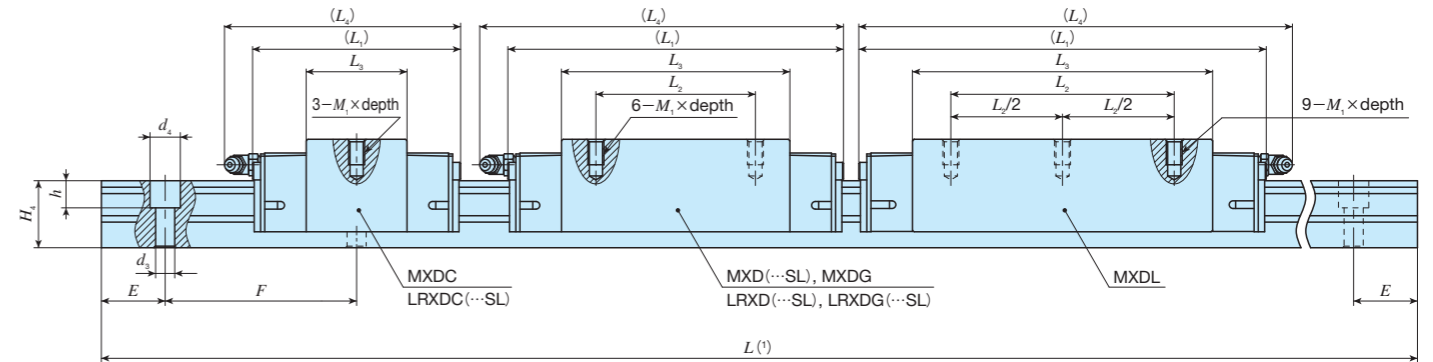
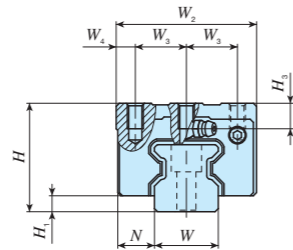

Model number		Interchangeable	Mass (Ref.)		Dimensions of assembly mm			Dimensions of slide unit mm							Dimensions of track rail mm						Mounting bolt for track rail (2)	Basic dynamic load rating (3) C N	Basic static load rating (3) C0 N	Static moment rating (3)					
MX	LRX (Non C-Lube)		Slide unit kg	Track rail kg/m	H	H1	N	W2	W3	W4	L1	L2	L3	L4	M1 x depth	H3	W	H4	d3	d4				h	E	F	Bolt size x length	T0 N·m	Tx N·m
MXDC 25	LRXDC 25	○	0.36	3.59	40	6	12.5	48	17.5	6.5	74	-	36	83	M6 x 12	9	23	24.5	7	11	9	30	60	M6 x 25	21 600	33 800	500	213 1 810	213 1 810
-	LRXDC 25-SL	○	0.55								98	35	60	107											32 100	56 300	833	573 3 800	573 3 800
MXD 25	LRXD 25	○	0.68								113	50	75	122											38 200	70 300	1 040	885 5 380	885 5 380
MXD 25-SL	LRXD 25-SL	○	0.88								137	70	99	146											47 400	92 800	1 370	1 530 8 480	1 530 8 480
MXDG 25	LRXDG 25	○	0.60								85	-	42.4	95											29 200	44 600	808	329 2 740	329 2 740
-	LRXDG 25-SL	○	0.92								113	40	70.4	123											43 400	74 400	1 350	883 5 780	883 5 780
MXDL 25	-	-	1.18	134	60	91.4	144	53 200	96 700	1 750	1 470 8 740	1 470 8 740																	
MXDC 30	LRXDC 30	○	1.52	162	80	119.4	172	65 600	126 000	2 290	2 500 13 600	2 500 13 600																	
-	LRXDC 30-SL	○	0.92	113	40	70.4	123	43 400	74 400	1 350	883 5 780	883 5 780																	
MXD 30	LRXD 30	○	1.18	134	60	91.4	144	53 200	96 700	1 750	1 470 8 740	1 470 8 740																	
MXD 30-SL	LRXD 30-SL	○	1.52	162	80	119.4	172	65 600	126 000	2 290	2 500 13 600	2 500 13 600																	
MXDG 30	LRXDG 30	○	0.92	113	40	70.4	123	43 400	74 400	1 350	883 5 780	883 5 780																	
-	LRXDG 30-SL	○	1.18	134	60	91.4	144	53 200	96 700	1 750	1 470 8 740	1 470 8 740																	
MXDL 30	-	-	1.52	162	80	119.4	172	65 600	126 000	2 290	2 500 13 600	2 500 13 600																	

Notes (1) : Track rail lengths are shown in Table 2.1 and Table 2.2 on page II-153, and Table 2.3 and Table 2.4 on page II-154.

(2) : The appended track rail mounting bolts are hexagon socket head bolts of JIS B 1176 or equivalent. In stainless steel model, stainless steel bolts are appended. In assembled set of MX series, track rail mounting bolt is not appended.

(3) : The directions of basic dynamic load rating (C), basic static load rating (C0) and static moment rating (T0, Tx, Ty) are shown in the sketches below. The upper values in the Tx and Ty columns apply to one slide unit, and the lower values apply to two slide units in close contact.

(4) : For grease nipple specifications, see Table 15 on page II-166.

Remark : A mounting thread hole for grease nipple is provided on the left and right end plates respectively.

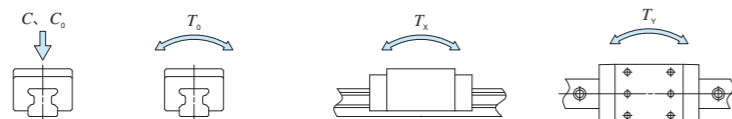

### Example of identification number of assembled set

Model code	Size	Part code	Material symbol	Preload symbol	Class symbol	Interchangeable code	Supplemental code
MXD	G	25	C2	R840	T1	P	S1 / F
①	②	③	④	⑤	⑥	⑦	⑧

<b>① Series</b> MXD Block type mounting from bottom LRXD	<b>② Length of slide unit</b> C Short No symbol Standard G High rigidity long L Extra high rigidity long	<b>③ Size</b> 25, 30	<b>④ Number of slide unit (two units)</b> 2, 3, 4, 5, 6, 7, 8, 9, 10	<b>⑤ Length of track rail (840mm)</b> R840	<b>⑥ Material symbol</b> No symbol High Carbon steel SL Stainless steel	<b>⑦ Preload amount</b> No symbol Standard T1 Light preload T2 Medium preload T3 Heavy preload	<b>⑧ Accuracy class</b> H High P Precision SP Super precision UP Ultra precision	<b>⑨ Interchangeable code</b> S1 Interchangeable specification S2 Interchangeable specification No symbol Non interchangeable specification	<b>⑩ Special specification</b> A, D, E, F, HP, I, J, L, LF, MA MN, N, Q, RC, T, UR, V, W, Y Z
--	--	-------------------------	---	---	---	--	--	--	--

# IKO C-Lube Linear Roller Way Super MX

## Block type mounting from top

**MXD • LRXD**

Shape

Size

10	12	15	20	25
30	35	45	55	65

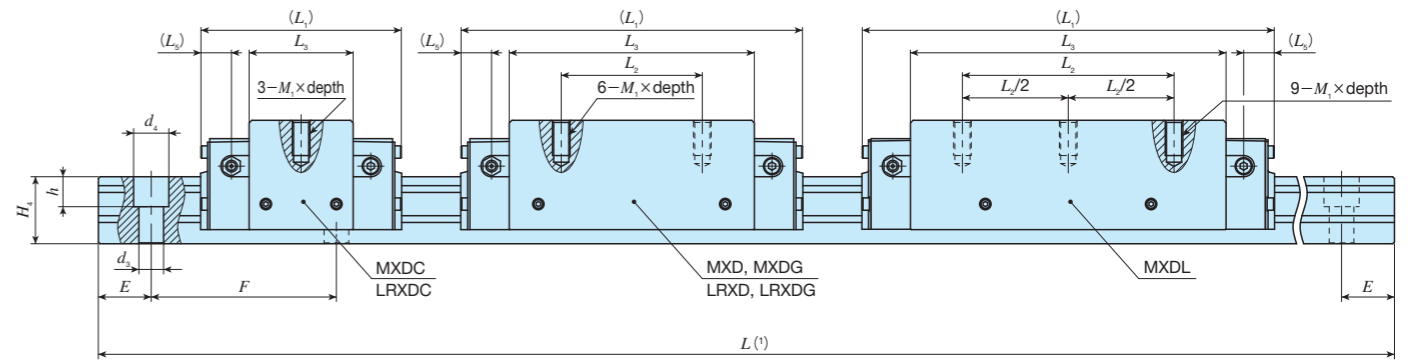
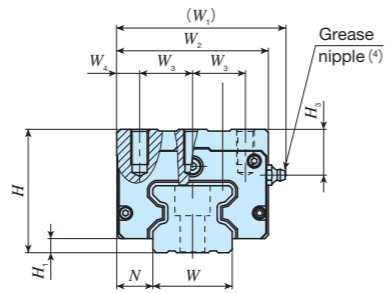

Model number	MX	LRX (Non C-Lube)	Interchangeable	Mass (Ref.)		Dimensions of assembly mm			Dimensions of slide unit mm							Dimensions of track rail mm							Mounting bolt for track rail (2)	Basic dynamic load rating (3)	Basic static load rating (3)	Static moment rating (3)					
				Slide unit kg	Track rail kg/m	H	H <sub>1</sub>	N	W <sub>1</sub>	W <sub>2</sub>	W <sub>3</sub>	W <sub>4</sub>	L <sub>1</sub>	L <sub>2</sub>	L <sub>3</sub>	L <sub>4</sub>	L <sub>5</sub>	M <sub>1</sub> × depth	H <sub>3</sub>	W	H <sub>4</sub>	d <sub>3</sub>				d <sub>4</sub>	h	E	F	Bolt size × length	C N
MXDC 35		LRXDC 35	○	0.97	6.88	55	6.5	18	78	70	25	10	92	-	46.6	12.7	M 8×16	20	34	32	9	14	12	40	80	M 8×35	39 500	60 000	1 300	506 3 950	506 3 950
MXD 35		LRXD 35	○	1.52									124	50	78.6	12.7															
MXDG 35		LRXDG 35	○	2.02									152	72	106.6	12.7															
MXDL 35		-	○	2.55									184	100	138.6	12.7															
MXDC 45		LRXDC 45	○	2.01	10.8	70	8	20.5	97	86	30	13	114	-	59	17.5	M10×20	26	45	38	14	20	17	52.5	105	M12×40	64 100	95 600	2 660	1 010 7 800	1 010 7 800
MXD 45		LRXD 45	○	3.13									154	60	99												12.5				
MXDG 45		LRXDG 45	○	4.29									194	80	139																
MXDL 45		-	○	5.36									234	120	179																

Notes (1) : Track rail lengths are shown in Table 2.1 on page II-153 and Table 2.3 on page II-154.

(2) : The appended track rail mounting bolts are hexagon socket head bolts of JIS B 1176 or equivalent. In assembled set of MX series, track rail mounting bolt is not appended.

(3) : The directions of basic dynamic load rating (C), basic static load rating (C<sub>0</sub>) and static moment rating (T<sub>0</sub>, T<sub>x</sub>, T<sub>y</sub>) are shown in the sketches below. The upper values in the T<sub>x</sub> and T<sub>y</sub> columns apply to one slide unit, and the lower values apply to two slide units in close contact.

(4) : For grease nipple specifications, see Table 15 on page II-166.

Remark : Three female threaded holes for grease nipple are prepared on each end plate.

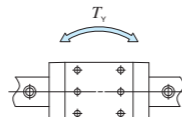
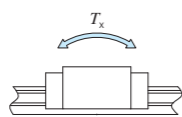
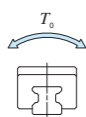
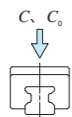

### Example of identification number of assembled set

Model code	Size	Part code	Preload symbol	Class symbol	Interchangeable code	Supplemental code
<b>MXD</b>	<b>G</b>	<b>35</b>	<b>C2</b>	<b>R1200</b>	<b>T2</b>	<b>P</b>
<b>S1</b>	<b>/F</b>					

① Series	
MXD	Block type mounting from bottom
LRXD	

② Length of slide unit	
C	Short
No symbol	Standard
G	High rigidity long
L	Extra high rigidity long

③ Size	35, 45
--------	--------

④ Number of slide unit (two units)	
------------------------------------	--

⑤ Length of track rail (1200mm)	
---------------------------------	--

⑥ Preload amount	
No symbol	Standard
T <sub>1</sub>	Light preload
T <sub>2</sub>	Medium preload
T <sub>3</sub>	Heavy preload

⑦ Accuracy class	
H	High
P	Precision
SP	Super precision
UP	Ultra precision

⑧ Interchangeable code	
S1	Interchangeable specification
S2	Interchangeable specification
No symbol	Non interchangeable specification

⑨ Special specification	
A, D, E, F, HP, I, J, L, LF, MA, MN, N, PS, Q, RC, T, UR, V, W, Y, Z	

# IKO C-Lube Linear Roller Way Super MX

## Block type mounting from top

MXD • LRXD

Shape



Size

10	12	15	20	25
30	35	45	55	65

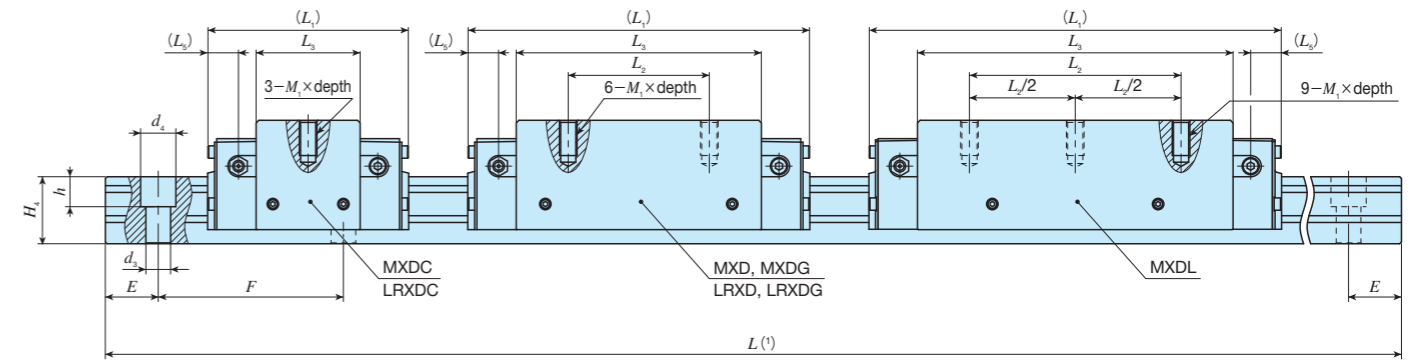
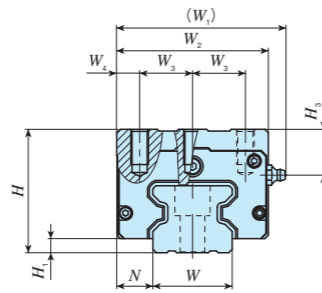

Model number	Interchangeable	Mass (Ref.)		Dimensions of assembly mm			Dimensions of slide unit mm							Dimensions of track rail mm							Mounting bolt for track rail (2)	Basic dynamic load rating (3)	Basic static load rating (3)	Static moment rating (3)						
		Slide unit kg	Track rail kg/m	H	H1	N	W1	W2	W3	W4	L1	L2	L3	L5	M1 x depth	H3	W	H4	d3	d4				h	E	F	C	C0	T0	Tx
MXDC 55	LRXDC 55	○	3.17	14.1	80	9	23.5	111	100	37.5	12.5	136	-	72	20	M12x25	26	53	43	16	23	20	60	120	M14x45	99 700	149 000	4 830	1 880	1 880
MXD 55	LRXD 55	○	4.97									184	75	120												5 040	5 040			
MXDG 55	LRXDG 55	○	7.06									238	95	174												10 400	10 400			
MXDL 55	-	-	9.08									292	150	228												17 700	17 700			
MXDC 65	LRXDC 65	○	5.52	22.6	90	12	31.5	136	126	38	25	180	-	95	26.3	M16x25	18	63	56	18	26	22	75	150	M16x60	174 000	249 000	9 790	4 200	4 200
MXD 65	LRXD 65	○	8.70									181	70	159												4 200	4 200			
MXDG 65	LRXDG 65	○	12.1									244	120	223												11 300	11 300			
MXDL 65	-	-	15.5									245	200	295												19 300	19 300			

Notes (1) : Track rail lengths are shown in Table 2.1 on page II-153 and Table 2.3 on page II-154.  
 (2) : The appended track rail mounting bolts are hexagon socket head bolts of JIS B 1176 or equivalent. In assembled set of MX series, track rail mounting bolt is not appended.  
 (3) : The directions of basic dynamic load rating (C), basic static load rating (C0) and static moment rating (T0, Tx, Ty) are shown in the sketches below. The upper values in the Tx and Ty columns apply to one slide unit, and the lower values apply to two slide units in close contact.

Remarks 1 : For grease nipple specifications, see Table 15 on page II-166.  
 2 : Three female threaded holes for grease nipple are prepared on each end plate.

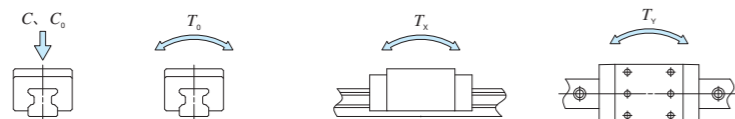

### Example of identification number of assembled set

Model code    Size    Part code    Preload symbol    Class symbol    Interchangeable code    Supplemental code

**MXD**   **G**   **55**   **C2**   **R3000**   **T2**   **P**   **S1**   **/F**

①   ②   ③   ④   ⑤   ⑥   ⑦   ⑧   ⑨

① Series MXD LRXD	Block type mounting from bottom	③ Size 55, 65	⑥ Preload amount No symbol Standard T1 Light preload T2 Medium preload T3 Heavy preload	⑧ Interchangeable code S1 Interchangeable specification S2 Interchangeable specification No symbol Non interchangeable specification
② Length of slide unit C Short No symbol Standard G High rigidity long L Extra high rigidity long	⑤ Length of track rail (3000mm)	⑦ Accuracy class H High P Precision SP Super precision UP Ultra precision	⑨ Special specification A, D, E, F, HP, I, J, L, LF, MA MN, PS, Q, RC, T, UR, V, W Y, Z	



# IKO C-Lube Linear Roller Way Super MX

Compact block type mounting from top

Shape	MXS • LRXS			
Size	15	20	25	30
	35	45	55	

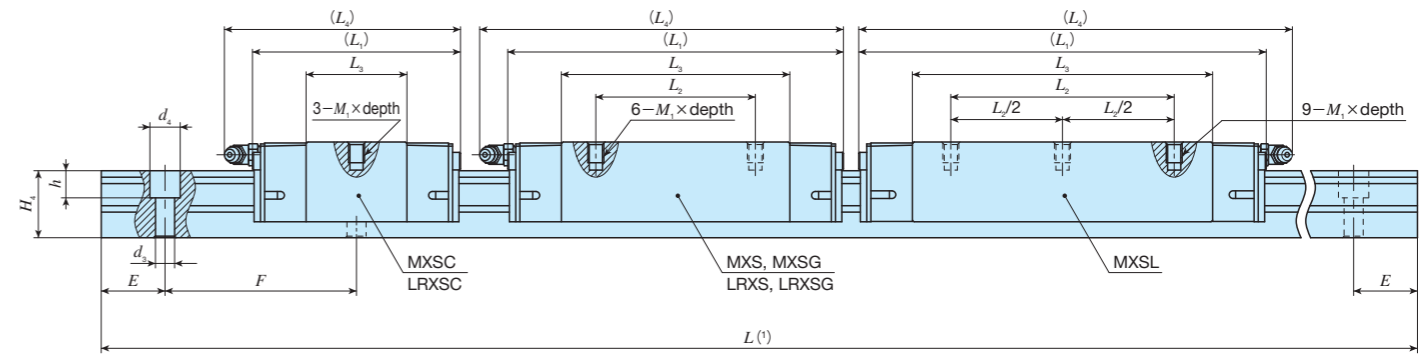
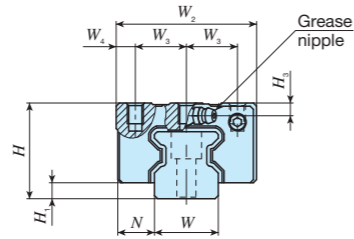

Model number	LRX (Non C-Lube)	Interchangeable	Mass (Ref.)		Dimensions of assembly mm			Dimensions of slide unit mm							Dimensions of track rail mm							Mounting bolt for track rail (3)	Basic dynamic load rating (4) C N	Basic static load rating (4) C0 N	Static moment rating (4)				
			Slide unit kg	Track rail kg/m	H	H1	N	W2	W3	W4	L1	L2	L3	L4	M1 x depth (2)	H3	W	H4	d3	d4	h				E	F	Bolt size x length	T0 N·m	Tx N·m
MXSC 15	LRXSC 15	○	0.099	1.65	24	4	9.5	34	13	4	52	-	24	55	M4 x 5.5	3.5	15	16.5	4.5	8	6	30	60	M4 x 16	7 730	12 000	113	50.6 457	50.6 457
MXS 15	LRXS 15	○	0.15								68	26	40	71											11 500	20 000	188	136 942	136 942
MXSG 15	LRXSG 15	○	0.21								84	56	87	14 900											28 000	263	262 1 590	262 1 590	
MXSC 20	LRXSC 20	○	0.21								66	-	31.6	74											16 100	26 400	341	150 1 260	150 1 260
MXS 20	LRXS 20	○	0.31	2.73	30	5	12	44	16	6	86	36	51.6	94	M5 x 6.5	4	20	21	6	9.5	8.5	30	60	M5 x 20	23 400	42 700	550	379 2 520	379 2 520
MXSG 20	LRXSG 20	○	0.42								106	50	71.6	114											30 100	58 900	760	713 4 200	713 4 200
MXSL 20	-	-	0.55								128	70	94.1	137											37 200	77 200	996	1 210 6 560	1 210 6 560
MXSC 25	LRXSC 25	○	0.30								74	-	36	83											21 600	33 800	500	213 1 810	213 1 810
MXS 25	LRXS 25	○	0.47	3.59	36	6	12.5	48	17.5	6.5	98	35	60	107	M6 x 9	5	23	24.5	7	11	9	30	60	M6 x 25	32 100	56 300	833	573 3 800	573 3 800
MXSG 25	LRXSG 25	○	0.57								113	50	75	122											38 200	70 300	1 040	885 5 380	885 5 380
MXSL 25	-	-	0.74								137	70	99	146											47 400	92 800	1 370	1 530 8 480	1 530 8 480
MXSC 30	LRXSC 30	○	0.54								85	-	42.4	95											29 200	44 600	808	329 2 740	329 2 740
MXS 30	LRXS 30	○	0.83	5.01	42	6.5	16	60	20	10	113	40	70.4	123	M8 x 11	6.5	28	28	9	14	12	40	80	M8 x 28	43 400	74 400	1 350	883 5 780	883 5 780
MXSG 30	LRXSG 30	○	1.05								134	60	91.4	144											53 200	96 700	1 750	1 470 8 740	1 470 8 740
MXSL 30	-	-	1.37								162	80	119.4	172											65 600	126 000	2 290	2 500 13 600	2 500 13 600

- Notes (1) : Track rail lengths are shown in Table 2.1 on page II-153 and Table 2.3 on page II-154.  
 (2) : Insertion screw depth for slide units are recommended as shown in Table 16.1 on page II-168.  
 (3) : The appended track rail mounting bolts are hexagon socket head bolts of JIS B 1176 or equivalent. In assembled set of MX series, track rail mounting bolt is not appended.  
 (4) : The directions of basic dynamic load rating (C), basic static load rating (C0) and static moment rating (T0, Tx, Ty) are shown in the sketches below. The upper values in the Tx and Ty columns apply to one slide unit, and the lower values apply to two slide units in close contact.  
 (5) : For grease nipple specifications, see Table 15 on page II-166.  
 Remark : A mounting thread hole for grease nipple is provided on the left and right end plates respectively.

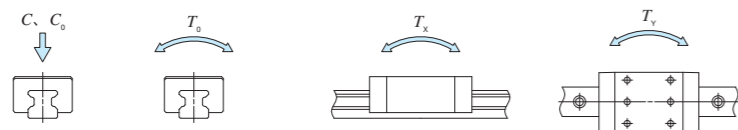

### Example of identification number of assembled set

Model code    Size    Part code    Preload symbol    Class symbol    Interchangeable code    Supplemental code  
**MXS**    **G**    **25**    **C2**    **R840**    **T1**    **P**    **S1**    **/F**

① Series MXS Compact block type mounting from bottom LRXS	② Length of slide unit C Short No symbol Standard G High rigidity long L Extra high rigidity long	③ Size 15, 20, 25, 30	④ Number of slide unit (two units)	⑤ Length of track rail (840mm)	⑥ Preload amount No symbol Standard T1 Light preload T2 Medium preload T3 Heavy preload	⑦ Accuracy class H High P Precision SP Super precision UP Ultra precision	⑧ Interchangeable code S1 Interchangeable specification S2 Interchangeable specification No symbol Non interchangeable specification	⑨ Special specification A, D, E, F, HP, I, J, L, LF, MA MN, N, Q, RC, T, UR, V, W Y, Z
---	---	--------------------------	------------------------------------	--------------------------------	---	---	---	---

# IKO C-Lube Linear Roller Way Super MX

## Compact block type mounting from top

Shape	<b>MXS</b>			
Size	<b>15</b>	<b>20</b>	<b>25</b>	<b>30</b>
	<b>35</b>	<b>45</b>	<b>55</b>	

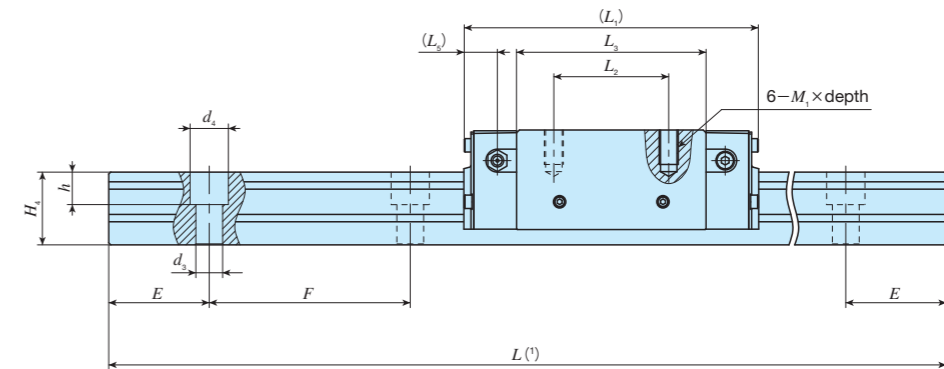
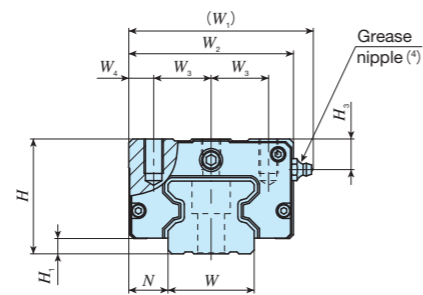

Model number	MX	LRX (Non C-Lube)	Interchangeable	Mass (Ref.)		Dimensions of assembly mm			Dimensions of slide unit mm							Dimensions of track rail mm						Mounting bolt for track rail <sup>(2)</sup> Bolt size×length	Basic dynamic load rating <sup>(3)</sup> C N	Basic static load rating <sup>(3)</sup> C <sub>0</sub> N	Static moment rating <sup>(3)</sup>						
				Slide unit kg	Track rail kg/m	H	H <sub>1</sub>	N	W <sub>1</sub>	W <sub>2</sub>	W <sub>3</sub>	W <sub>4</sub>	L <sub>1</sub>	L <sub>2</sub>	L <sub>3</sub>	L <sub>5</sub>	M <sub>1</sub> ×depth	H <sub>3</sub>	W	H <sub>4</sub>	d <sub>3</sub>				d <sub>4</sub>	h	E	F	T <sub>0</sub> N·m	T <sub>x</sub> N·m	T <sub>y</sub> N·m
MXS 35		-	○	1.22	6.88	48	6.5	18	78	70	25	10	124	50	78.6	12.7	M 8×12	13	34	32	9	14	12	40	80	M 8×35	58 700	100 000	2 170	1 360	1 360
MXSG 35		-	○	1.61		60	8	20.5	97	86	30	13	152	72	106.6												17.5	M10×18	16	45	38
MXS 45		-	○	2.37	10.8	60	8	20.5	97	86	30	13	154	60	99	17.5	M10×18	16	45	38	14	20	17	52.5	105	M12×40	95 400	159 000	4 430	2 700	2 700
MXSG 45		-	○	3.27		70	9	23.5	111	100	37.5	12.5	194	80	139												20	M12×20	16	53	43
MXS 55		-	○	3.96	14.1	70	9	23.5	111	100	37.5	12.5	184	75	120	20	M12×20	16	53	43	16	23	20	60	120	M14×45	148 000	248 000	8 040	5 040	5 040
MXSG 55		-	○	5.63		70	9	23.5	111	100	37.5	12.5	238	95	174												20	M12×20	16	53	43

Notes<sup>(1)</sup> : Track rail lengths are shown in Table 2.1 on page II-153 and Table 2.3 on page II-154.

<sup>(2)</sup> : Track rail mounting bolts are not appended.

<sup>(3)</sup> : The directions of basic dynamic load rating (C), basic static load rating (C<sub>0</sub>) and static moment rating (T<sub>0</sub>, T<sub>x</sub>, T<sub>y</sub>) are shown in the sketches below. The upper values in the T<sub>x</sub> and T<sub>y</sub> columns apply to one slide unit, and the lower values apply to two slide units in close contact.

<sup>(4)</sup> : For grease nipple specifications, see Table 15 on page II-166.

Remark : Three female threaded holes for grease nipple are prepared on each end plate.

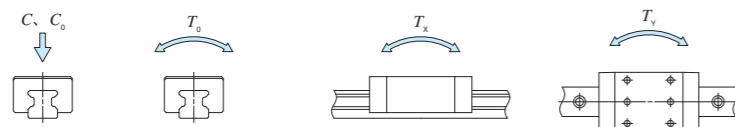

### Example of identification number of assembled set

Model code    Size    Part code    Preload symbol    Class symbol    Interchangeable code    Supplemental code

**MXS**   **G**   **45**   **C2**   **R1470**   **T1**   **P**   **S1**   **/F**

①   ②   ③   ④   ⑤   ⑥   ⑦   ⑧   ⑨

① Series	MXS Compact block type mounting from bottom	③ Size	35, 45, 55	⑥ Preload amount	No symbol Standard T <sub>1</sub> Light preload T <sub>2</sub> Medium preload T <sub>3</sub> Heavy preload	⑧ Interchangeable code	S1 Interchangeable specification S2 Interchangeable specification No symbol Non interchangeable specification
② Length of slide unit	No symbol Standard G High rigidity long	④ Number of slide unit (two units)		⑦ Accuracy class	H High P Precision SP Super precision UP Ultra precision	⑨ Special specification	A, D, E, F, HP, I, J, L, LF, MA N, RC, T, UR, V, W, Z
⑤ Length of track rail (1470mm)							

# IKO C-Lube Linear Roller Way Super MX

## Low section flange type mounting from top

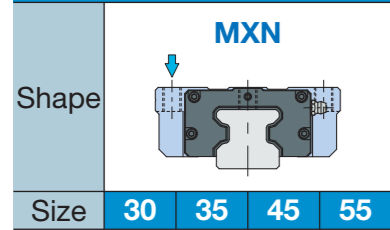

MXN 30  
MXNG 30  
MXNL 30

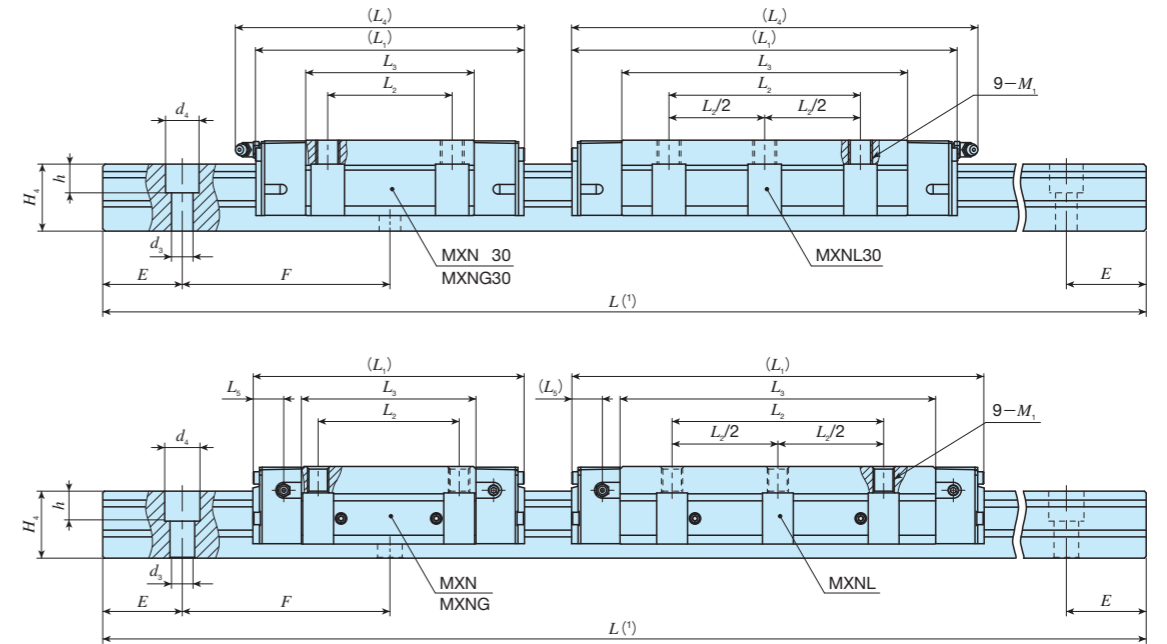
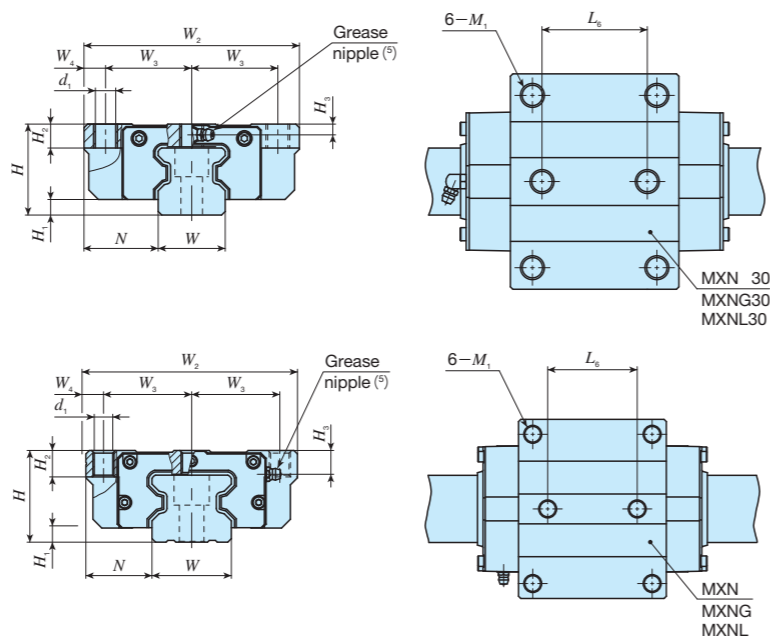

Model number	LRX (Non C-Lube)	Interchangeable	Mass (Ref.)		Dimensions of assembly mm			Dimensions of slide unit mm										Dimensions of track rail mm						Mounting bolt for track rail <sup>(3)</sup> Bolt size×length	Basic dynamic load rating <sup>(4)</sup> C	Basic static load rating <sup>(4)</sup> C <sub>0</sub>	Static moment rating <sup>(4)</sup>							
			Slide unit kg	Track rail kg/m	H	H <sub>1</sub>	N	W <sub>2</sub>	W <sub>3</sub>	W <sub>4</sub>	L <sub>1</sub>	L <sub>2</sub>	L <sub>3</sub>	L <sub>4</sub>	L <sub>5</sub>	L <sub>6</sub>	d <sub>1</sub>	M <sub>1</sub>	Maximum screwing depth <sup>(2)</sup>	H <sub>2</sub>	H <sub>3</sub>	W	H <sub>4</sub>				d <sub>3</sub>	d <sub>4</sub>	h	E	F	T <sub>0</sub>	T <sub>x</sub>	T <sub>y</sub>
MXN 30	-	○	1.05	5.01	38	6.5	31	90	36	9	113	52	70.4	121	-	44	8.5	M10	9	10	4.5	28	28	9	14	12	40	80	M 8×28	43 400	74 400	1 350	883	883
MXNG 30	-	○	1.38								134	91.4	142	5 780																5 780				
MXNL 30	-	-	1.75								162	119.4	170	8 740																8 740				
MXN 35	-	○	1.55	6.88	44	6.5	33	100	41	9	124	62	78.6	-	52	8.5	M10	11	13	11	34	32	9	14	12	40	80	M 8×35	58 700	100 000	2 170	1 360	1 360	
MXNG 35	-	○	2.13								152	106.6	12.7																13 800	13 800				
MXNL 35	-	-	2.71								184	138.6	-																21 300	21 300				
MXN 45	-	○	2.58	10.8	52	8	37.5	120	50	10	154	80	99	-	60	10.5	M12	13	15	13.5	45	38	14	20	17	52.5	105	M12×40	95 400	159 000	4 430	2 700	2 700	
MXNG 45	-	○	3.73								194	139	17.5																16 800	16 800				
MXNL 45	-	-	4.72								234	179	-																29 000	29 000				
MXN 55	-	○	4.61	14.1	63	9	43.5	140	58	12	184	95	120	-	70	12.5	M14	19	17	16	53	43	16	23	20	60	120	M14×45	148 000	248 000	8 040	5 040	5 040	
MXNG 55	-	○	6.94								238	174	20																10 400	10 400				
MXNL 55	-	-	8.87								292	228	-																17 700	17 700				

Notes<sup>(1)</sup> : Track rail lengths are shown in Table 2.1 on page II-153 and Table 2.3 on page II-154.  
<sup>(2)</sup> : It is recommended to secure actual screwing depth should not exceed the maximum screwing depth in the table.  
<sup>(3)</sup> : Track rail mounting bolts are not appended.  
<sup>(4)</sup> : The directions of basic dynamic load rating (C), basic static load rating (C<sub>0</sub>) and static moment rating (T<sub>0</sub>, T<sub>x</sub>, T<sub>y</sub>) are shown in the sketches below. The upper values in the T<sub>x</sub> and T<sub>y</sub> columns apply to one slide unit, and the lower values apply to two slide units in close contact.  
<sup>(5)</sup> : For grease nipple specifications, see Table 15 on page II-166.

Remarks 1 : In size 30, a grease nipple mounting thread hole is provided on the left and right end plates respectively.  
 2 : In size 35, 45 and 55, three female threaded holes for grease nipple are prepared on each end plate. In size 35, thread size of front face is smaller than other threads thus, please consult **IKO** if grease nipple for front face is required.

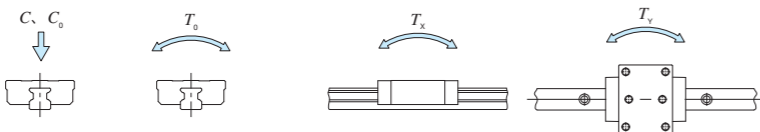

### Example of identification number of assembled set

Model code: MXN, Size: G, Part code: 55, Preload symbol: C2, Class symbol: R3000, Interchangeable code: T2, Supplemental code: P, S1, /F

① Series MXN Low section flange type mounting from top	② Length of slide unit No symbol Standard G High rigidity long L Extra high rigidity long	③ Size 30, 35, 45, 55	④ Number of slide unit (two units)	⑤ Length of track rail (3000mm)	⑥ Preload amount No symbol Standard T1 Light preload T2 Medium preload T3 Heavy preload	⑦ Accuracy class H High P Precision SP Super precision UP Ultra precision	⑧ Interchangeable code S1 Interchangeable specification S2 Interchangeable specification No symbol Non interchangeable specification	⑨ Special specification A, D, E, F, HP, I, J, L, LF, MA RC, T, UR, V, W, Z
--	--	--------------------------	------------------------------------	---------------------------------	---	---	---	--

# IKO C-Lube Linear Roller Way Super MX

## Low section block type mounting from top

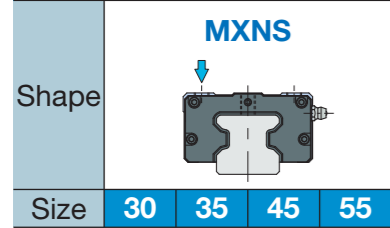

MXNS 30  
MXNSG 30  
MXNSL 30

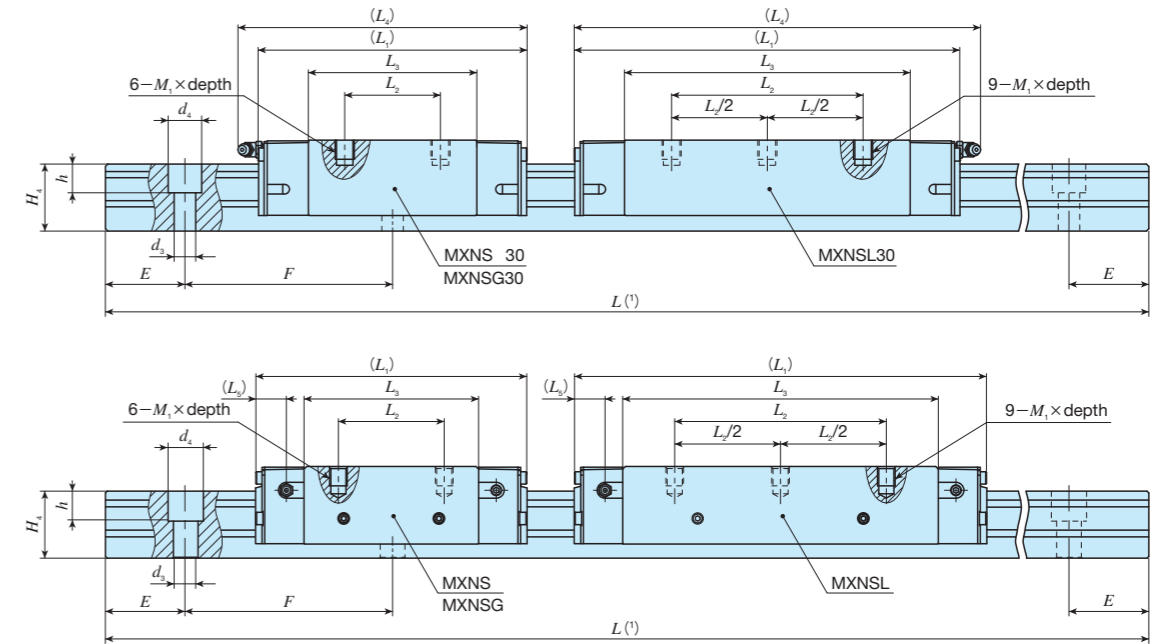
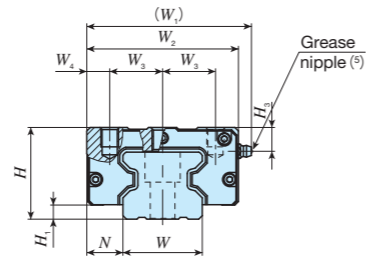
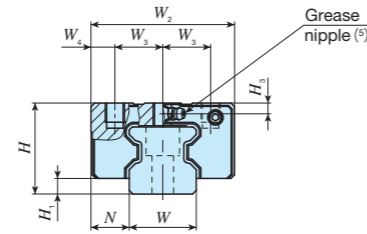

Model number	LRX (Non C-Lube)	Interchangeable	Mass (Ref.)		Dimensions of assembly mm		Dimensions of slide unit mm										Dimensions of track rail mm		Mounting bolt for track rail <sup>(3)</sup>	Basic dynamic load rating <sup>(4)</sup>	Basic static load rating <sup>(4)</sup>	Static moment rating <sup>(4)</sup>										
			Slide unit kg	Track rail kg/m	H	H <sub>1</sub>	N	W <sub>1</sub>	W <sub>2</sub>	W <sub>3</sub>	W <sub>4</sub>	L <sub>1</sub>	L <sub>2</sub>	L <sub>3</sub>	L <sub>4</sub>	L <sub>5</sub>	M <sub>1</sub> × depth <sup>(2)</sup>	Maximum screwing depth <sup>(2)</sup>				H <sub>3</sub>	W	H <sub>4</sub>	d <sub>3</sub>	d <sub>4</sub>	h	E	F	Bolt size × length	C	C <sub>0</sub>
MXNS 30	-	○	0.70	5.01	38	6.5	16	-	60	20	10	113	40	70.4	121	-	M 8 × 8	9	4.5	28	28	9	14	12	40	80	M 8 × 28	43 400	74 400	1 350	883	883
MXNSG 30	-	○	0.90		53 200	96 700	1 750	5 780	1 470																							
MXNSL 30	-	-	1.14		65 600	126 000	2 290	13 600	2 500																							
MXNS 35	-	○	1.08	6.88	44	6.5	18	78	70	25	10	124	50	78.6	-	M 8 × 9	11	11	34	32	9	14	12	40	80	M 8 × 35	58 700	100 000	2 170	1 360	1 360	
MXNSG 35	-	○	1.42		74 200	135 000	2 930	13 800	2 440																							
MXNSL 35	-	-	1.81		90 800	175 000	3 800	21 300	4 060																							
MXNS 45	-	○	1.84	10.8	52	8	20.5	94	86	30	13	154	60	99	-	M10 × 11	13	13.5	45	38	14	20	17	52.5	105	M12 × 40	95 400	159 000	4 430	2 700	2 700	
MXNSG 45	-	○	2.58		124 000	223 000	6 200	29 000	5 220																							
MXNSL 45	-	-	3.29		151 000	287 000	7 980	44 400	8 560																							
MXNS 55	-	○	3.31	14.1	63	9	23.5	111	100	37.5	12.5	184	75	120	-	M12 × 15	19	16	53	43	16	23	20	60	120	M14 × 45	148 000	248 000	8 040	5 040	5 040	
MXNSG 55	-	○	4.83		198 000	359 000	11 700	57 000	10 400																							
MXNSL 55	-	-	6.28		244 000	470 000	15 300	90 700	17 700																							

Notes<sup>(1)</sup>: Track rail lengths are shown in Table 2.1 on page II-153 and Table 2.3 on page II-154.  
<sup>(2)</sup>: Insertion screw depth of slide unit mounting holes are shown in Table 16.2 on page II-168. It is recommended to secure actual screwing depth should not exceed the maximum screwing depth in the table.  
<sup>(3)</sup>: Track rail mounting bolts are not appended.  
<sup>(4)</sup>: The directions of basic dynamic load rating (C), basic static load rating (C<sub>0</sub>) and static moment rating (T<sub>0</sub>, T<sub>x</sub>, T<sub>y</sub>) are shown in the sketches below. The upper values in the T<sub>x</sub> and T<sub>y</sub> columns apply to one slide unit, and the lower values apply to two slide units in close contact.  
<sup>(5)</sup>: For grease nipple specifications, see Table 15 on page II-166.

Remarks 1: In size 30, a grease nipple mounting thread hole is provided on the left and right end plates respectively.  
 2: In size 35, 45 and 55, three female threaded holes for grease nipple are prepared on each end plate. In size 35, thread size of front face is smaller than other threads thus, please consult IKO if grease nipple for front face is required.

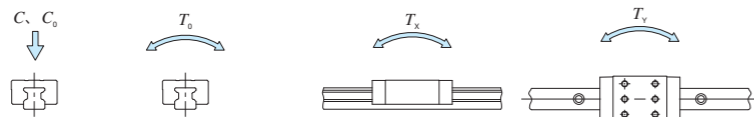

### Example of identification number of assembled set

Model code: MXNS, Size: G, Part code: 55, Preload symbol: C2, Class symbol: R3000, Interchangeable code: T2, Supplemental code: P, S1, /F

① Series MXNS Low section Block type mounting from top	② Length of slide unit G High rigidity long L Extra high rigidity long	③ Size 30, 35, 45, 55	④ Number of slide unit (two units)	⑤ Length of track rail (3000mm)	⑥ Preload amount No symbol Standard T1 Light preload T2 Medium preload T3 Heavy preload	⑦ Accuracy class H High P Precision SP Super precision UP Ultra precision	⑧ Interchangeable code S1 Interchangeable specification S2 Interchangeable specification No symbol Non interchangeable specification	⑨ Special specification A, D, E, F, HP, I, J, L, LF, MA RC, T, UR, V, W, Z
---	--	--------------------------	------------------------------------	---------------------------------	---	---	---	--

## Linear Roller Way X



# Linear Roller Way X

# LRWX

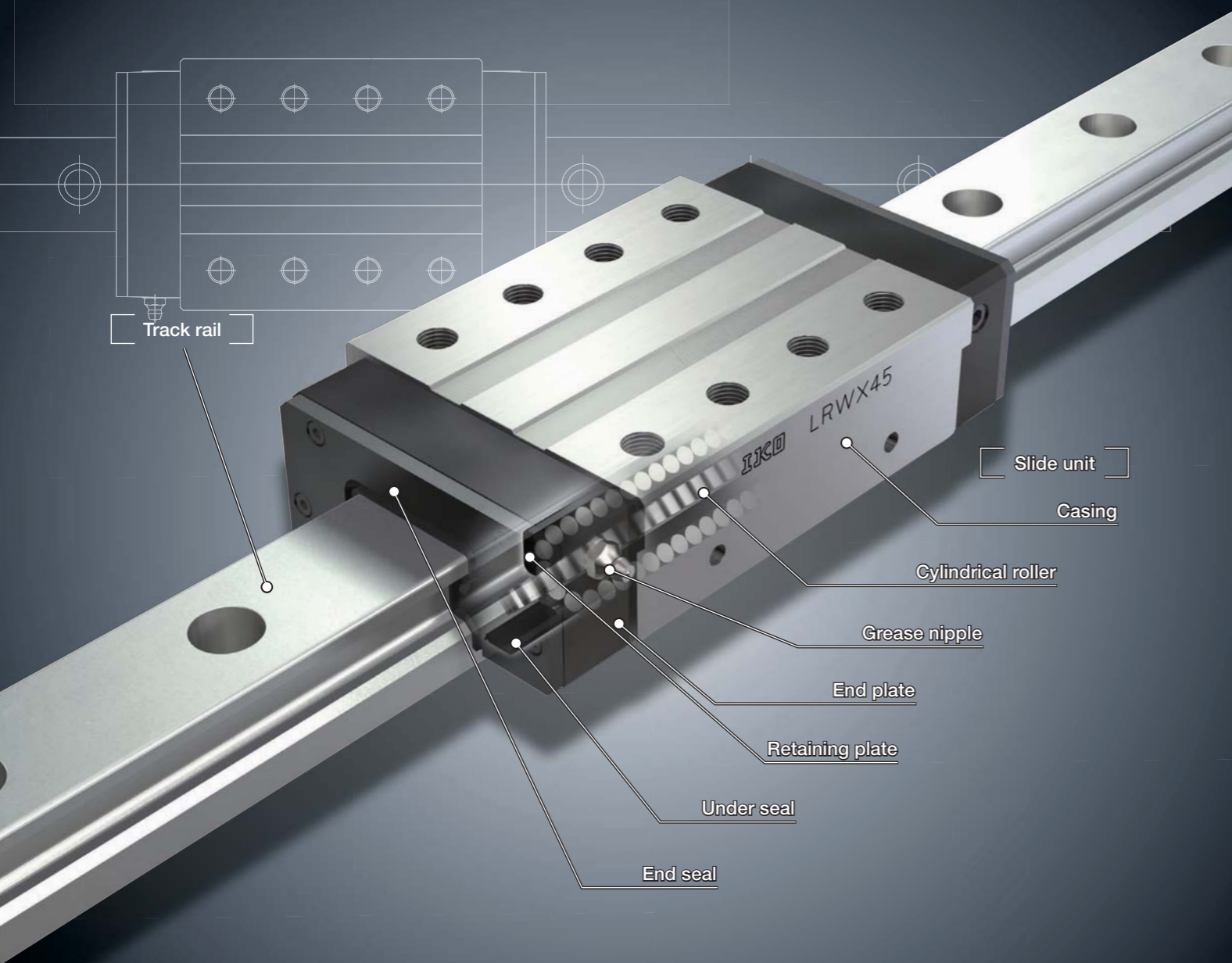
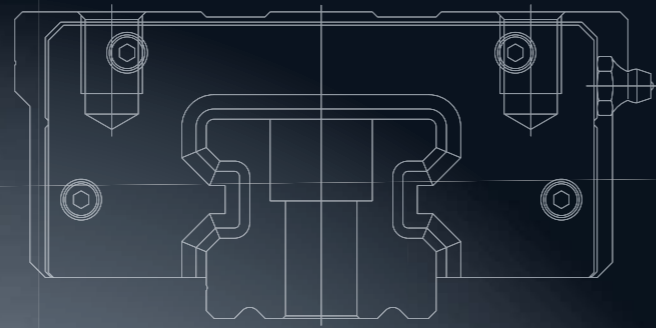

***Roller type linear motion rolling guide with cylindrical rollers in four-rows!***

***Balanced roller arrangement provides stable load capacity in all direction!***

***Two shapes of slide unit, flanged type and block type are available for optimal products to fit for requirement of machine and equipment!***

## Identification number and specification

The specification of Linear Roller way X is indicated by the identification number, consisting of a model code, a size, a part code, a preload symbol, a classification symbol and any supplemental code.

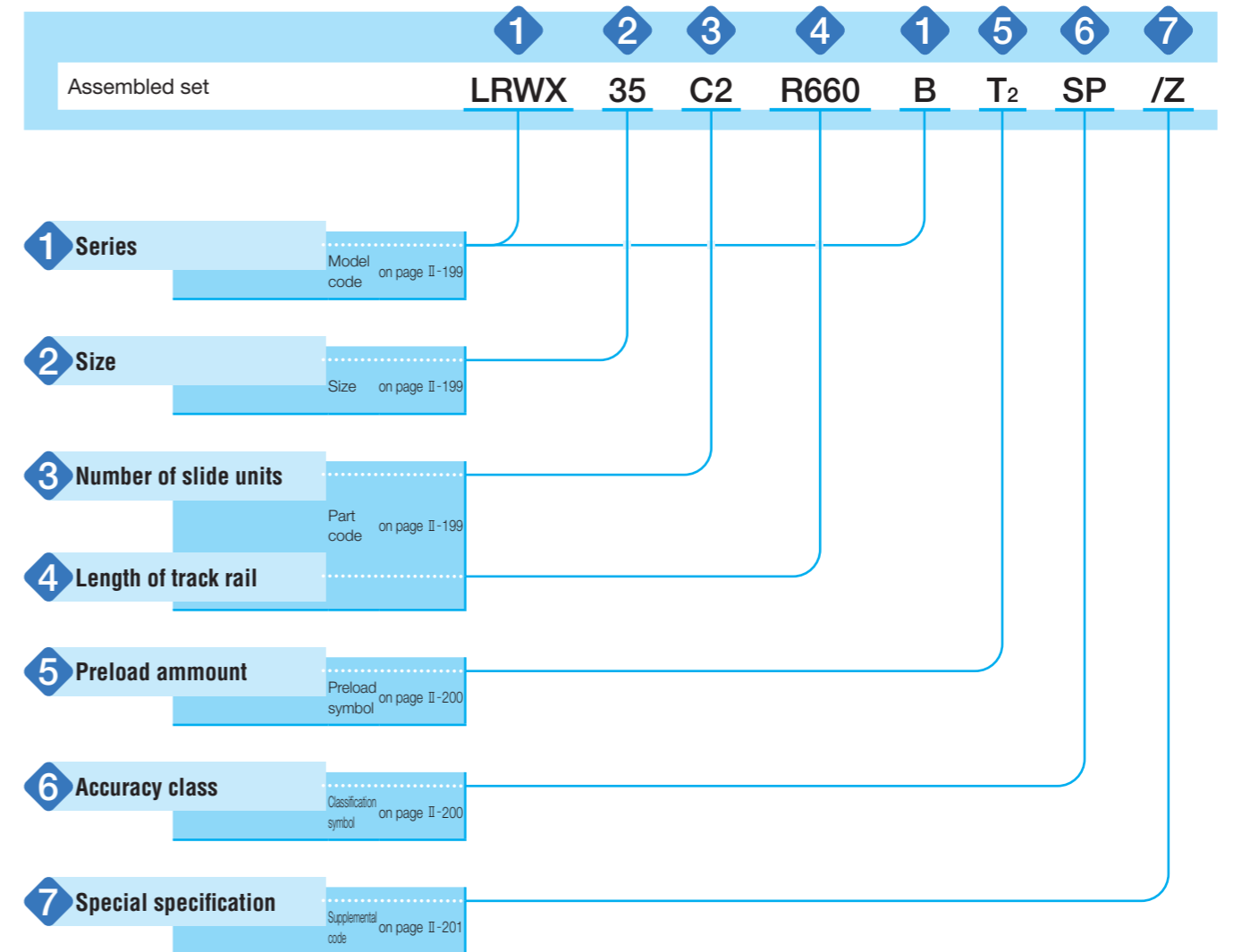

LRWX

Identification number and specification —Series · Size of rolling guide · Number of slide units · Length of track rail—

<b>1 Series</b>	Linear Roller Way X <sup>(1)</sup>	Block type mounting from top : LRWX···B Flange type mounting from bottom : LRWXH
	Applicable size and shape of slide unit are shown in Table1. Note <sup>(1)</sup> Linear Roller Way without C-lube.	
<b>2 Size</b>	25, 35, 45, 55, 75	Applicable size and shape of slide unit are shown in Table1.
<b>3 Number of slide units</b>	: ○	For an assembled set, indicates the number of slide units assembled on track rail.
<b>4 Length of track rail</b>	: R○	Indicate the length of track rail in mm. For standard and maximum lengths, see "Track rail length" in Table 2.

Table 1 Type and size

Shape	Model code	Size				
		25	35	45	55	75
Block type mounting from top 	LRWX···B	○	○	○	○	○
Flange type mounting from bottom 	LRWXH	—	○	○	○	○

Table 2 Standard and maximum length of track rail



Item	Model number	LRWX25···B	LRWX25···B/HP <sup>(3)</sup>	LRWX 35···B LRWXH35	LRWX 45···B LRWXH45	LRWX 55···B LRWXH55	LRWX 75···B LRWXH65
Standard length $L(n)$		480 ( 8)	480 (16)	480 ( 8)	800 (10)	800 ( 8)	840 ( 7)
		660 (11)	660 (22)	660 (11)	1040 (13)	1000 (10)	1200 (10)
		840 (14)	840 (28)	840 (14)	1200 (15)	1200 (12)	1560 (13)
		1020 (17)	1020 (34)	1020 (17)	1520 (19)	1500 (15)	1920 (16)
		1200 (20)	1200 (40)	1200 (20)	1920 (24)	2000 (20)	3000 (30)
		1500 (25)	1500 (50)	1500 (25)		3000 (30)	
Pitch of mounting holes $F$		60	30	60	80	100	120
$E$		30	15	30	40	50	60
Standard range of $E^{(1)}$	Incl.	9	9	12	15	18	23
	under	39	24	42	55	68	83
Maximum length <sup>(2)</sup>		1980 (3000)	1980 (3000)	3000 (3960)	2960 (4000)	3000 (4000)	3000 (3960)

unit : mm

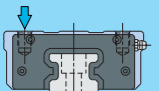
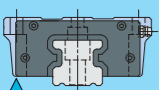
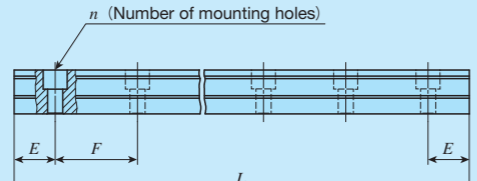
Notes<sup>(1)</sup> : Not applicable to the track rail with female threads for bellows (supplemental code "J")  
<sup>(2)</sup> : Track rails with the maximum lengths shown in parentheses can also be manufactured. Consult IKO for further information.  
<sup>(3)</sup> : Applicable for Half pitch of track rail mounting hole.

—Preload amount · Accuracy class · Special specification—

<b>5 Preload amount</b>	Standard	: No symbol	Specify this item for an assembled set or a single slide unit. For applicable preload amount, see Table3. For details of preload amount, see Table4.
	Light preload	: T <sub>1</sub>	
	Medium preload	: T <sub>2</sub>	
	Heavy preload	: T <sub>3</sub>	
<b>6 Accuracy class</b>	High	: H	For details of accuracy, see Table3.
	Precision	: P	
	Super precision	: SP	
	Ultra precision	: UP	

Table 3 Preload amount

Preload type	Symbol	Preload amount N	Application
Standard	(No Symbol)	0 <sup>(1)</sup>	· Very smooth motion · Minimum vibration
Light preload	T <sub>1</sub>	0.02 C <sub>0</sub>	· Load is evenly balanced · Smooth and precise motion
Medium preload	T <sub>2</sub>	0.05 C <sub>0</sub>	· Medium vibration · Medium overhung load
Heavy preload	T <sub>3</sub>	0.08 C <sub>0</sub>	· Vibration and / or shocks · Large overhung load · Heavy cutting

Note<sup>(1)</sup> : Zero or minimal amount of preload.  
 Remark : C<sub>0</sub> means the basic static load rating.

Table 4 Accuracy

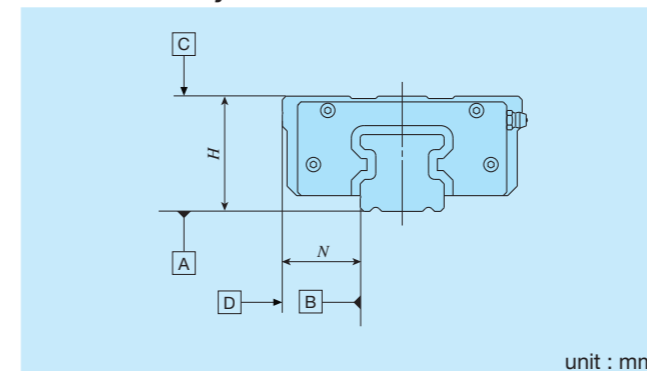

Classification (Symbol)	High (H)	Precision (P)	Super precision (SP)	Ultra precision (UP)
Dim. $H$ tolerance	±0.040	±0.020	±0.010	±0.008
Dim. $N$ tolerance	±0.050	±0.025	±0.015	±0.010
Dim. variation of $H^{(1)}$	0.015	0.007	0.005	0.003
Dim. variation of $N^{(1)}$	0.020	0.010	0.007	0.003
Dim. variation of $H$ for multiple assembled sets <sup>(2)</sup>	0.035	0.025	—	—
Parallelism in operation of C to A	See Fig.1			
Parallelism in operation of D to B	See Fig.1			

Note<sup>(1)</sup> : It means the size variation between slide units mounted on the same track rail.

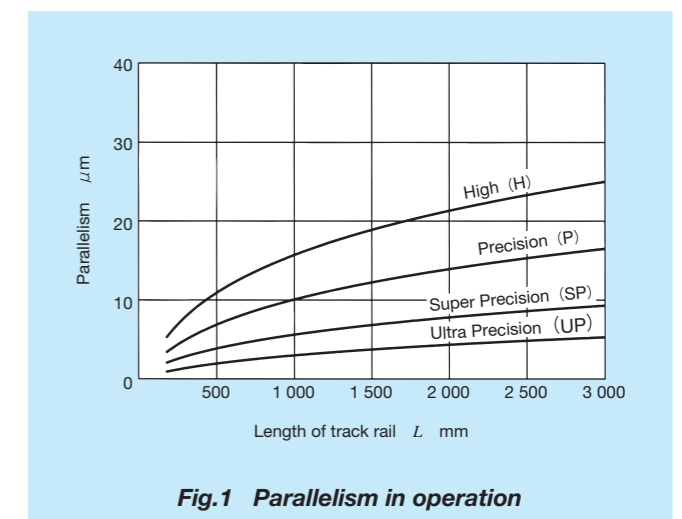

Fig.1 Parallelism in operation

7 Special specification

/A, /D, /E, /F, /HP, /I, /JO, /LO, /LFO, /Q, /NO, /WO, /YO, /ZO

For applicable special specifications, see Table 5. When several special specifications are combined, see Table 6. For details of special specifications, see page III-17.

Table 5 Special specifications

Optional specification	Supplemental code	Size				
		25	35	45	55	75
Butt-jointing track rails	/A	○	○	○	○	○
Opposite reference surfaces arrangement	/D	○	○	○	○	○
Specified rail mounting hole positions	/E	○	○	○	○	○
Caps for rail mounting holes	/F	○	○	○	○	○
Half pitch of track rail mounting hole	/HP	○	×	×	×	×
Inspection sheet	/I	○	○	○	○	○
Female threads for bellows	/JO	○	○	○	○	○
Black chrome surface treatment	/LO	○	○	○	○	○
Fluorine black chrome surface treatment	/LFO	○	○	○	○	○
C-Lube plates	/Q	○	○	○	○	○
Double end seals	/NO	○	×	×	×	×
Matched sets to be used as assembled group	/WO	○	○	○	○	○
Specified grease	/YO	○	○	○	○	○
Scrapers	/ZO	○	○	○	○	○

Table 6 Combination of special specifications

D	○												
E	—	—											
F	○	○	○										
HP	—	○	—	○									
I	○	○	○	○	○								
J	○	○	○	○	—	○							
L	○	○	○	○	○	○	○						
LF	○	○	○	○	○	○	○	—					
Q	○	○	○	○	○	○	○	○	○				
V	○	○	○	○	○	○	○	○	○	—			
W	○	○	—	○	○	○	○	○	○	○	○		
Y	○	○	○	○	○	○	○	○	○	○	○	○	
Z	○	○	○	○	○	○	○	○	○	○	○	○	○
	A	D	E	F	HP	I	J	L	LF	Q	V	W	Y

Remarks 1 : The mark — indicates that this combination cannot be made.

2 : if a combination of special specifications is required, indicate the supplemental codes in alphabetical order.

Table 7 Female threads for bellow mounting (Supplemental code /J, /JJ)

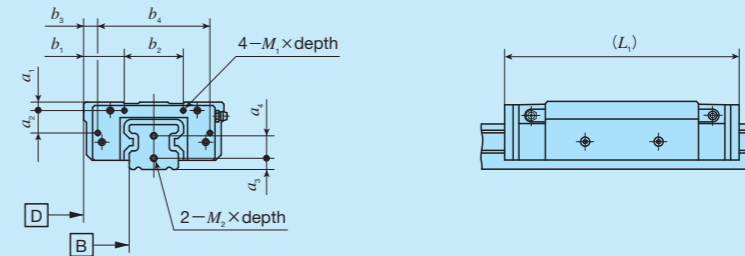

unit : mm

Model number	Slide unit								Track rail		
	a <sub>1</sub>	a <sub>2</sub>	b <sub>1</sub>	b <sub>2</sub>	b <sub>3</sub>	b <sub>4</sub>	M <sub>1</sub> × depth	L <sub>1</sub> <sup>(1)</sup>	a <sub>3</sub>	a <sub>4</sub>	M <sub>2</sub> × depth
LRWX 25...B	5	12	15	33	7	49	M3 × 6	116	7	12	M4 × 8
LRWX 35...B	6	16	29	42	10	80	M3 × 6	166	8	16	M4 × 8
LRWXH 35			31		12						
LRWX 45...B	8	20	34	52	12	96	M4 × 8	221	10	19	M5 × 10
LRWXH 45			38		16						
LRWX 55...B	9	24	36	68	15	110	M5 × 10	282	12	23	M6 × 12
LRWXH 55			43		22						
LRWX 75...B	10	35	35	110	15.5	149	M5 × 10	366	15	30	M6 × 12
LRWXH 75			42		22.5						

Note (1) : The vales for the slide unit with female threads for bellow mounting at the both sides.

Table 8 Slide unit with C-Lube plateas(Supplemental code /Q)

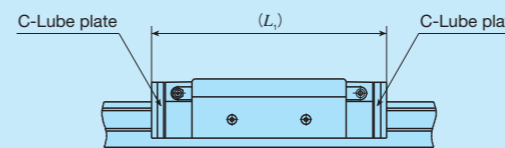

unit : mm

Size	L <sub>1</sub>
25	120
35	166
45	218
55	275
75	364

Remark : The values for the slide unit with C-Lube plates at both ends.

Table 9 Slide unit with scrapers (Supplementa code /ZZ)

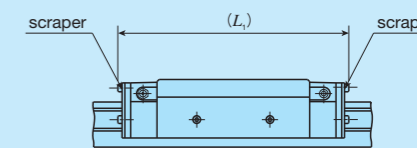

unit : mm

Size	L <sub>1</sub>
25	120
35	164
45	217
55	275
75	361

Remark : The values for the slide unit with scrapers at both ends.

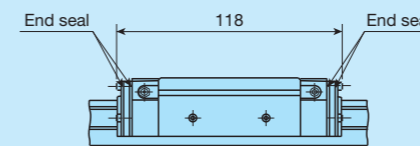

Fig. 2 Silde unit with double end seals (Size 25) (Supplemental code /V, /VV)

Remark : The vales for the slide unit with double end seals at both-ends.

# Lubrication

Lithium-soap base grease (ALVANIA grease EP 2 : SHELL) is pre-packed in LRWX series slide units. LRWX series are provided with grease nipple shown in Table 10.

**Table 10 Parts of lubrication**

Size	Grease nipple <sup>(1)</sup>	Applicable supply nozzle	Nominal size of female threads for piping
25	JIS 1 type	Grease gun available on the market	M6
35			
45	JIS 2 type		PT1/8
55			
75			

Note<sup>(1)</sup> : See Table15.2 on Page III-22 for specifications of grease nipples.

# Dust Protection

Linear Roller Way X is protected from dust by special rubber seals. But, if large amount of fine contaminants are present, or if large particles of foreign matters such as dust or chips may fall on the track rail, it is recommended to provide protective covers such as bellows for the entire linear motion mechanism. Bellows to match the dimensions of Linear Roller Way X are optionally available. They are easy to mount and highly effective for dust protection. If required consult.

# Precautions for Use

**①Mounting surface, reference mounting surface, and general mounting structure**

To mount Linear Roller Way X, correctly fit the reference mounting surfaces B and D of the slide unit and the track rail to the reference mounting surfaces of the table and the bed, and then fix them tightly. (See Figs. 3.)

The reference mounting surfaces B and D and mounting surfaces A and C of Linear Roller Way X are accurately finished by grinding. Stable and high accuracy linear motion can be obtained by finishing the mating mounting surfaces of machines or equipment with high accuracy and correctly mounting the guide on these surfaces.

The slide unit reference mounting surface is always the side surface opposite to the **I KO** mark. The track rail reference mounting surface is identified by locating the **I KO** mark on the top surface of the track rail. The track rail reference mounting surface is the side surface above the **I KO** mark (in the direction of the arrow). (See Figs. 4.)

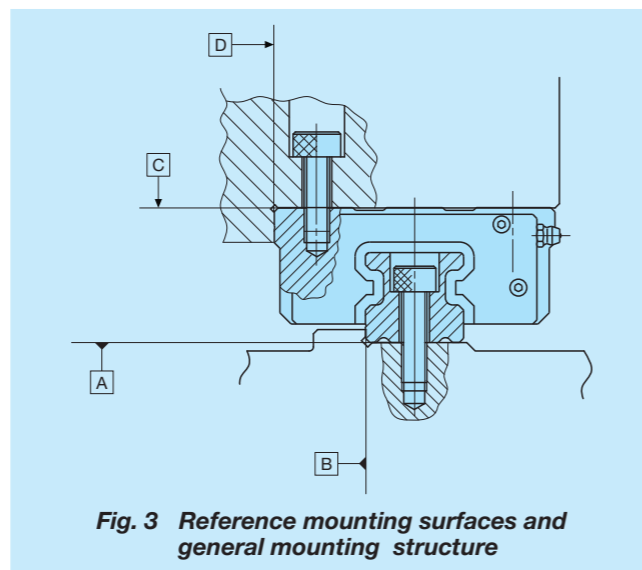

**Fig. 3 Reference mounting surfaces and general mounting structure**

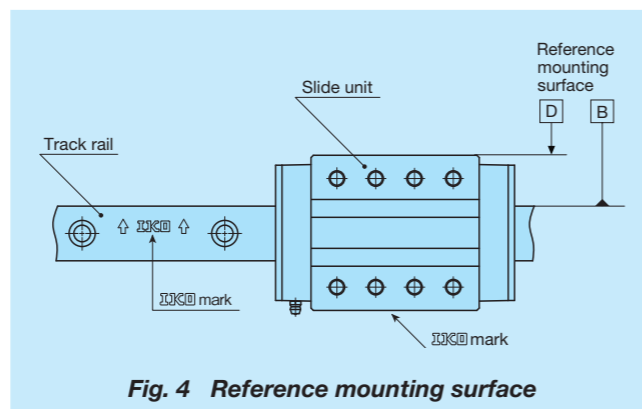
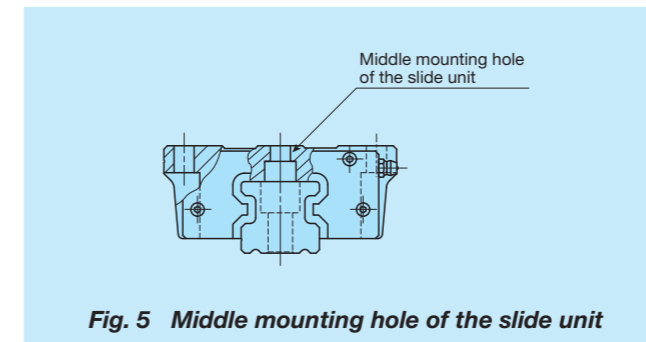

**Fig. 4 Reference mounting surface**

**②Mounting slide unit**

In the slide unit of LRWX25...B and LRWXH, mounting holes are also prepared on the middle of slide unit to support any direction of load and moment in good balance.

It is recommended to fix all mounting hokes to have full performance of products.



**Fig. 5 Middle mounting hole of the slide unit**

**③Corner radius and shoulder height of reference mounting surface**

It is recommended to make a relieved fillet at the corner of the mating reference mounting surfaces as shown in Fig. 6. Otherwise, corner radius *R* is recommended shown in Table 11. Table 11 shows recommended shoulder heights and radius of the reference mounting surfaces.

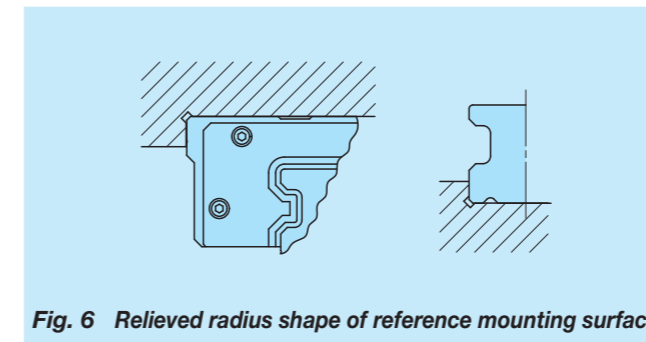

**Fig. 6 Relieved radius shape of reference mounting surface**

**Table 11 Corner radius and shoulder height of reference mounting surfaces**

Size	Slide unit	Track rail	Relieved radius <i>R</i> (max.)
	Shoulder height <i>h</i> <sub>1</sub>	Shoulder height <i>h</i> <sub>2</sub>	
25	6	4	1
35	8	5.5	1
45	8	6	1
55	10	8	1.5
75	10	8	1.5

unit : mm

**④Tightening torque of mounting bolts**

The standard torque values for Linear Roller Way X mounting bolts are shown Table 12. When machines or equipment are subjected to severe vibration, shock, large fluctuating load, or moment load, the bolts should be tightened with a torque 1.2 to 1.5 times higher than the standard torque values shown.

When the mating member material is cast iron or aluminum, tightening torque should be lowered in accordance with the strength characteristics of the material.

**Table 12 Tightening torque of mounting bolts**

Bolt size	Tightening torque N·m Carbon steel bolt
M 6 × 1	13.3
M 8 × 1.25	32.0
M10 × 1.5	62.7
M12 × 1.75	108
M16 × 2	263
M24 × 3	882

Remark : The recommended tightening torque is for strength division 12.9.



# IKO Linear Roller Way X

## Block type mounting from top

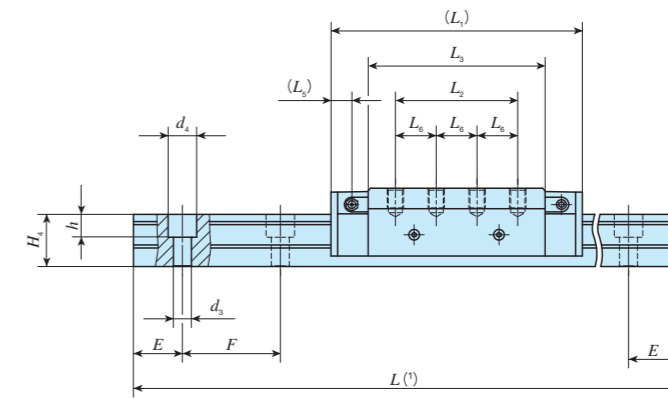
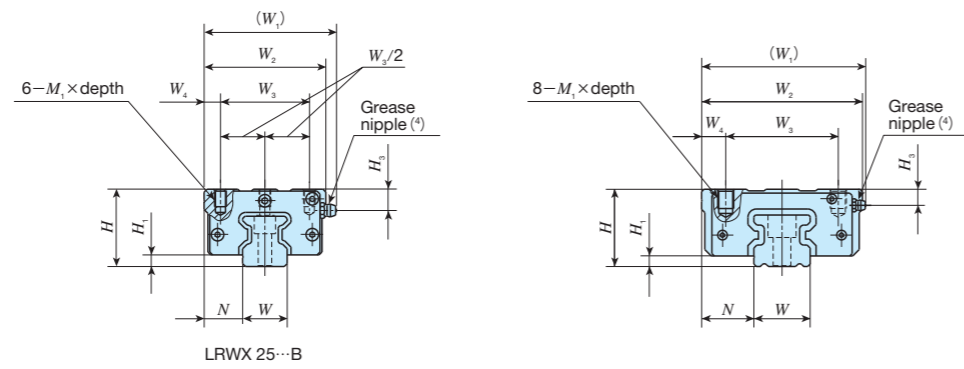
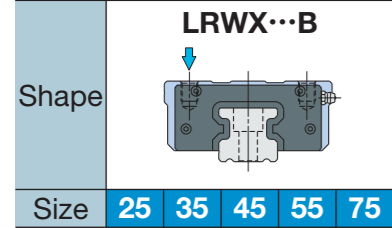

Model number	Mass(Ref.)		Dimensions of assembly mm			Dimensions of slide unit mm						Dimensions of track rail mm						Mounting bolt for track rail <sup>(3)</sup> Bolt size×length	Basic <sup>(4)</sup> dynamic load rating C N	Basic <sup>(4)</sup> static load rating C <sub>0</sub> N	Static moment rating <sup>(4)</sup>								
	Slide unit kg	Track rail kg/m	H	H <sub>1</sub>	N	W <sub>1</sub>	W <sub>2</sub>	W <sub>3</sub>	W <sub>4</sub>	L <sub>1</sub>	L <sub>2</sub>	L <sub>3</sub>	L <sub>5</sub>	L <sub>6</sub>	M <sub>1</sub> ×深さ	H <sub>3</sub>	W				H <sub>4</sub>	d <sub>3</sub>	d <sub>4</sub>	h	E	F	T <sub>0</sub> N·m	T <sub>x</sub> N·m	T <sub>y</sub> N·m
LRWX 25··B	0.93	3.70	40	6	20	70	63	46	8.5	109	45	74.4	11	—	M 6× 9	11	23	26	7	11	9	30	60	M 6×28	32 700	70 300	1 110	885 5 220	885 5 220
LRWX 35··B	2.65	6.66	48	6.5	32.5	104	100	70	15	154	75	108.4	12.8	25	M10×12	10	35	32	11	17.5	14	30	60	M10×35	49 900	91 100	2 150	1 660 9 450	1 660 9 450
LRWX 45··B	5.32	10.3	60	8	37.5	129	120	82	19	205	105	144	18.5	35	M12×16	14.5	45	39	14	20	16	40	80	M12×40	93 300	167 000	5 000	4 030 23 000	4 030 23 000
LRWX 55··B	9.09	15.3	70	9	42.5	146	140	95	22.5	262	135	189	24.5	45	M12×18	16	55	47	18	26	21	50	100	M16×50	186 000	330 000	12 200	10 700 57 900	10 700 57 900
LRWX 75··B	19.0	25.1	90	10	52.5	195	180	123	28.5	346	180	240	45	60	M16×25	20	75	57	26	39	30	60	120	M24×60	298 000	518 000	25 200	20 900 121 000	20 900 121 000

Notes (1) : Track rail lengths are shown in Table 2 on page II-199.  
 (2) : The appended track rail mounting bolts are hexagon socket head bolts of JIS B 1176 or equivalent. In assembled set of LRWX series, track rail mounting bolt is not appended.  
 (3) : The directions of basic dynamic load rating (C), basic static load rating (C<sub>0</sub>) and static moment rating (T<sub>0</sub>, T<sub>x</sub>, T<sub>y</sub>) are shown in the sketches below. The upper values in the T<sub>x</sub> and T<sub>y</sub> columns apply to one slide unit, and the lower values apply to two slide units in clode contact.  
 (4) : For grease nipple specifications, see Table 10 on page II-203.

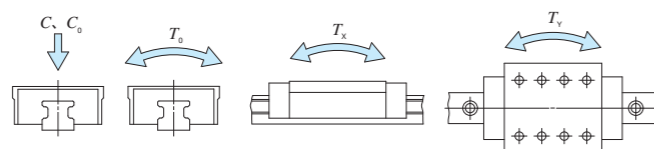

**Example of identification number of assembled set**

Model code	Size	Part code	Model code	Preload symbol	Class symbol	Supplemental code
<b>LRWX</b>	<b>35</b>	<b>C2 R840</b>	<b>B</b>	<b>T<sub>1</sub></b>	<b>P</b>	<b>/W2</b>
①	②	③	④	⑤	⑥	⑦

① Series  
LRWX··B Block type mounting from top

② Size  
25, 35, 45, 55, 75

③ Number of slide unit (two units)

④ Length of track rail (840mm)

⑤ Preload amount  
No symbol Standard  
T<sub>1</sub> Light preload  
T<sub>2</sub> Medium preload  
T<sub>3</sub> Heavy preload

⑥ Accuracy class  
H High  
P Precision  
SP Super precision  
UP Ultra precision

⑦ Special specification  
A, D, E, F, HP, I, J  
L, LF, Q, V, W, Y, Z



# IKO Linear Roller Way X

## Flange type mounting from bottom

Shape	LRWXH			
Size	35	45	55	75

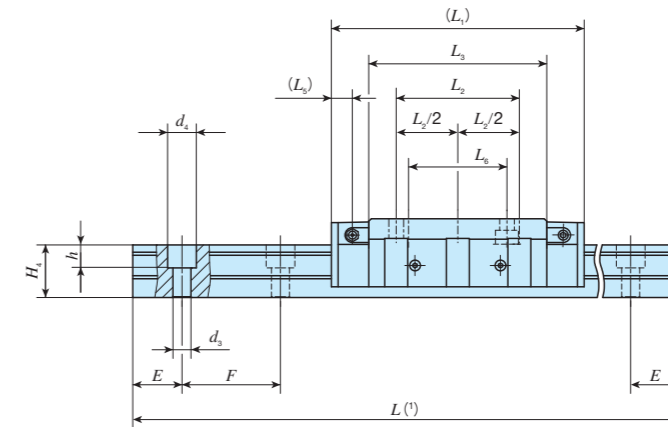
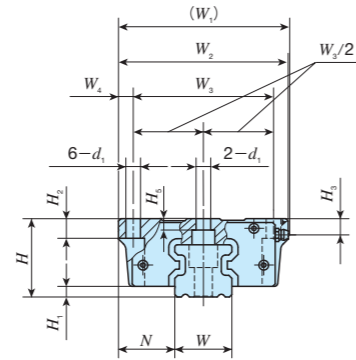
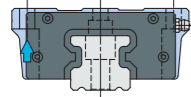

Model number	Mass(Ref.)		Dimensions of assembly mm			Dimensions of slide unit mm											Dimensions of track rail mm					Mounting bolt for track rail <sup>(3)</sup> Bolt size×length	Basic <sup>(4)</sup> dynamic load rating C N	Basic <sup>(4)</sup> static load rating C <sub>0</sub> N	Static moment rating <sup>(4)</sup>						
	Slide unit kg	Track rail kg/m	H	H <sub>1</sub>	N	W <sub>1</sub>	W <sub>2</sub>	W <sub>3</sub>	W <sub>4</sub>	L <sub>1</sub>	L <sub>2</sub>	L <sub>3</sub>	L <sub>5</sub>	L <sub>6</sub>	d <sub>1</sub>	H <sub>2</sub>	H <sub>3</sub>	H <sub>5</sub>	W	H <sub>4</sub>	d <sub>3</sub>				d <sub>4</sub>	h	E	F	T <sub>0</sub> N·m	T <sub>x</sub> N·m	T <sub>y</sub> N·m
LRWXH 35	2.51	6.66	48	6.5	34.5	106	104	86	9	154	75	108.4	12.8	60	9	12	10	7	35	32	11	17.5	14	30	60	M10×35	49 900	91 100	2 150	1 660 9 450	1 660 9 450
LRWXH 45	5.18	10.3	60	8	41.5	133	128	108	10	205	105	144	18.5	80	11	15	14.5	10	45	39	14	20	16	40	80	M12×40	93 300	167 000	5 000	4 030 23 000	4 030 23 000
LRWXH 55	9.08	15.3	70	9	49.5	—	154	130	12	262	135	189	24.5	106	14	18	16	10	55	47	18	26	21	50	100	M16×50	186 000	330 000	12 200	10 700 57 900	10 700 57 900
LRWXH 75	19.7	25.1	90	10	59.5	202	194	164	15	346	180	240	45	134	18	24	20	16	75	57	26	39	30	60	120	M24×60	298 000	518 000	25 200	20 900 121 000	20 900 121 000

Notes (1) : Track rail lengths are shown in Table 2 on page II-199.

(2) : The appended track rail mounting bolts are hexagon socket head bolts of JIS B 1176 or equivalent. In assembled set of LRWX series, track rail mounting bolt is not appended.

(3) : The directions of basic dynamic load rating (C), basic static load rating (C<sub>0</sub>) and static moment rating (T<sub>0</sub>, T<sub>x</sub>, T<sub>y</sub>) are shown in the sketches below. The upper values in the T<sub>x</sub> and T<sub>y</sub> columns apply to one slide unit, and the lower values apply to two slide units in close contact.

(4) : For grease nipple specifications, see Table 10 on page II-203.

1N=0.102kgf

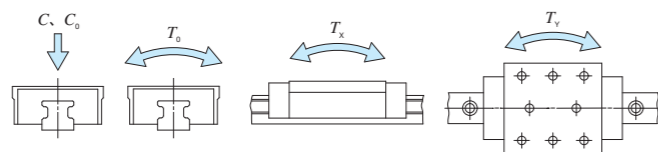

### Example of identification number of assembled set

Model code	Size	Part code	Preload symbol	Class symbol	Supplemental code
LRWXH	35	C2	R840	T1	P /W2
①	②	③	④	⑤	⑥ ⑦

① Series  
LRWXH Flange type mounting from bottom

② Size  
35, 45, 55, 75

③ Number of slide unit (two units)

④ Length of track rail (840mm)

⑤ Preload amount  
No symbol Standard  
T1 Light preload  
T2 Medium preload  
T3 Heavy preload

⑥ Accuracy class  
H High  
P Precision  
SP Super precision  
UP Ultra precision

⑦ Special specification  
A, D, E, F, HP, I, J  
L, LF, Q, V, W, Y, Z