

TwinTech **Ultimate** MEDICAL RANGE

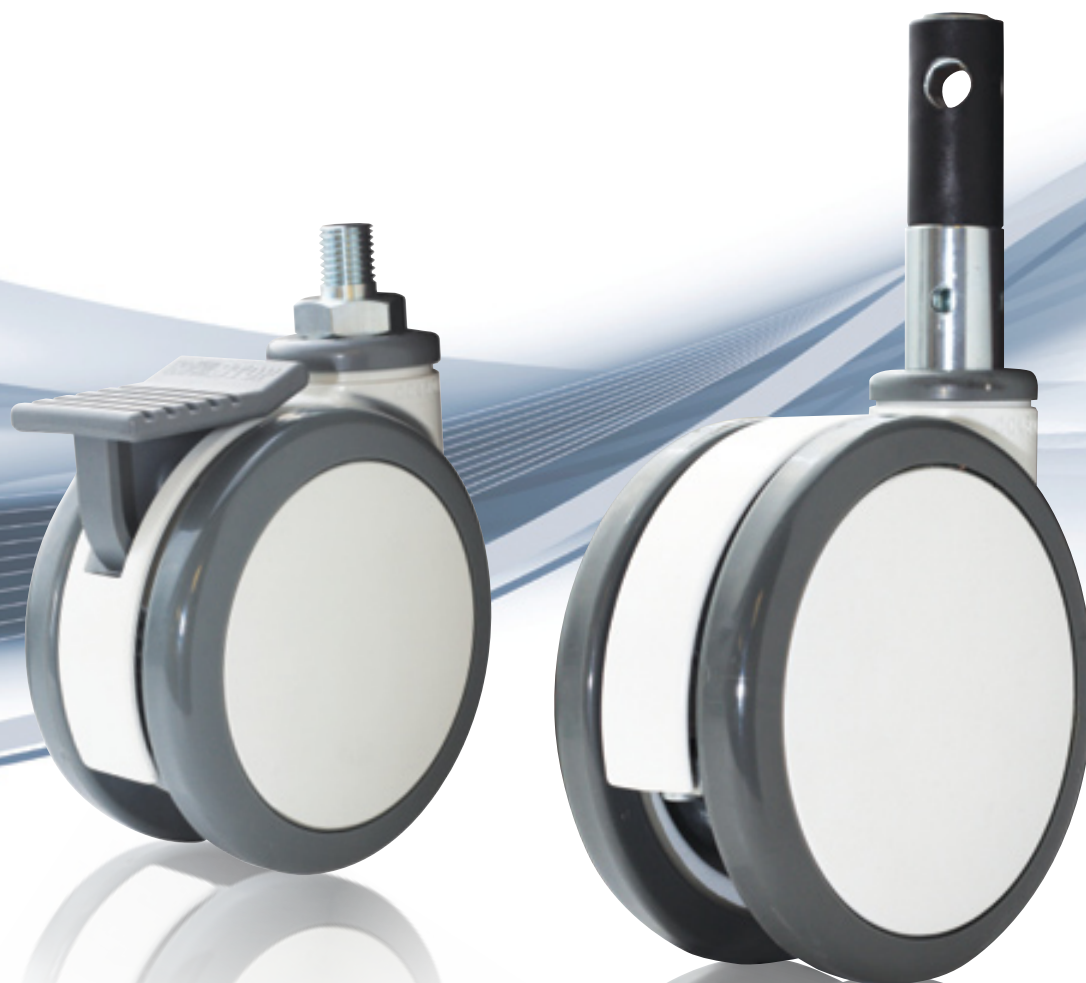

colson 

Solus



Twintech Ultimate "Solus" Castors for Institutional applications

Standard Fixing: Threaded stem

Functions: Free Swivel, Total Lock, Directional Lock

Standard colour: RAL 9003 white with Grey tyres, top cap and brake pedal (as shown).

Applications: Daycare beds, nursing home beds, Laser surgery equipment, Ultrasound units, Patient hoists, all medical equipment requiring a "designer" castor.

Options: Electrically conductive and washable versions; alternative fixings; custom colour wheel covers; SUPPRESS antimicrobial treatment - consult factory.

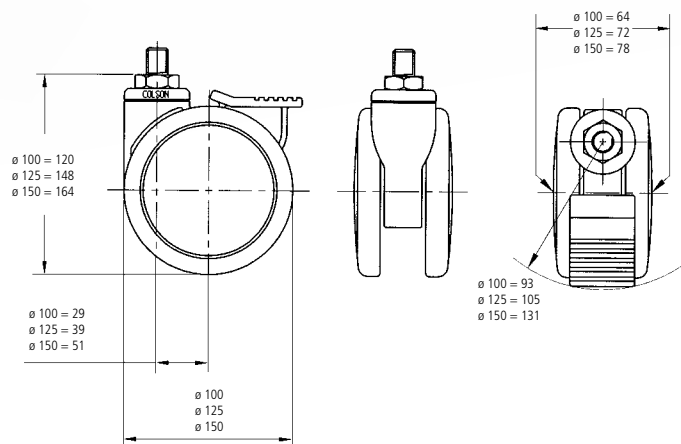

Conforms to: ISO 22881: 2004

Wheel Dia mm	Bearing	Load kg	Stem mm	Overall Height mm	Swivel Radius mm	Tyres	Swivel Code	Total Lock Code	Directional Lock Code
100	Precision	125	M12 x 20	120	93/90	Polyurethane	03 4504 409 007 0001 0805	03 4502 409 007 2001 0805	03 4507 404 007 5001 0805
125	Precision	135	M16 x 20	148	105/105	Polyurethane	03 5504 404 017 0001 0805	03 5502 404 017 2001 0805	03 5507 404 017 5001 0805
150	Precision	150	M16 x 20	169	131/131	Polyurethane	03 6504 404 017 0001 0805	03 6502 404 017 2001 0805	03 6507 404 017 5001 0805

Combi



Twintech Ultimate "Combi"

Castors for hospital beds and complex medical equipment

Standard Stems: 28x98mm, 32x52mm Central Locking

Functions: Free Swivel, Total Lock, Total and Directional Lock. 45 degree cam movement

Standard colour: RAL 9003 white with Grey tyres, top cap (as shown).

Applications: Hospital beds, care beds, anaesthesia machines, imaging equipment, laser surgery equipment, all equipment requiring a centrally-operated braking system in a "designer" castor.

Options: Electrically conductive and washable versions; 25x32mm Central Locking Stem – total lock only; 30 deg cams; custom colour wheel covers; SUPPRESS Antimicrobial treatment - consult factory

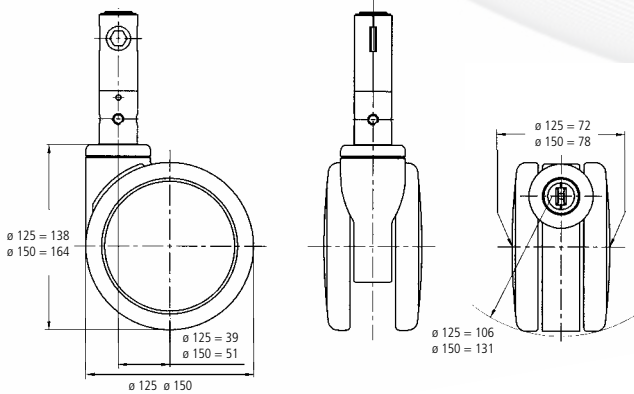

Conforms to: ISO 22882:2004



Wheel Dia mm	Bearing	Load kg	Stem mm	Overall Height mm	Swivel Radius mm	Tyres	Castor Code	
Swivel Castors								
125	Precision	135	27.8 x 40	138	105	Polyurethane	03 5514 404 001 0001 0805	
125	Precision	135	32 x 40	138	105	Polyurethane	03 5554 404 001 00010805	
125	Precision	135	25 x 31	148	105	Polyurethane	03 5594 404 203 0001 0805	
150	Precision	150	27.8 x 40	164	131	Polyurethane	03 6514 404 001 0001 0805	
150	Precision	150	32 x 40	164	131	Polyurethane	03 6554 404 001 0001 0805	
Total Lock Castors								
125	Precision	135	27.8 x 98	138	105	Polyurethane	03 5512 404 002 0001 0805	
125	Precision	135	32 x 52	138	105	Polyurethane	03 5552 404 198 00010805	
125	Precision	135	25 x 31	148	105	Polyurethane	03 5592 404 204 0001 0805	
150	Precision	150	27.8 x 98	164	131	Polyurethane	03 6512 404 002 0001 0805	
150	Precision	150	32 x 52	164	131	Polyurethane	03 6552 404 198 0001 0805	
Total Lock & Directional Lock Castors								
							Mode 03	Mode 04
125	Precision	135	27.8 x 98	138	105	Polyurethane	03 5513 404 003 0001 0805	03 5513 404 004 0001 0805
125	Precision	135	32 x 52	138	105	Polyurethane	03 5553 404 003 0001 0805	03 5553 404 004 0001 0805
150	Precision	150	27.8 x 98	164	131	Polyurethane	03 6513 404 003 0001 0805	03 6513 404 004 0001 0805
150	Precision	150	32 x 52	164	131	Polyurethane	03 6553 404 003 0001 0805	03 6553 404 004 0001 0805

Central Locking System Castors

When all the castors in a set need to be locked simultaneously, TwinTech **Ultimate** Combi castors provide the solution.

Brake Functions:

Total Lock – The brake simultaneously locks wheel rotation and swivelling action. Four castors will completely immobilise the equipment.

Total & Directional Lock – These castors have two brake positions: total lock and swivel lock only. Use of one or two of these castors in a set enables the equipment to be moved easily in a straight line and steered around corners in a controlled fashion, when 'Directional Lock' is selected.

Free Swivel – no braking action.

Some typical layouts are shown opposite. When Total & Directional Lock castors are used, it is important to specify the correct Mode, which denotes the position of the brake actuating bar, relative to the direction of travel, when the Directional Lock brake function is selected.

The typical castor layouts shown demonstrate Directional Lock Modes 03 and 04.

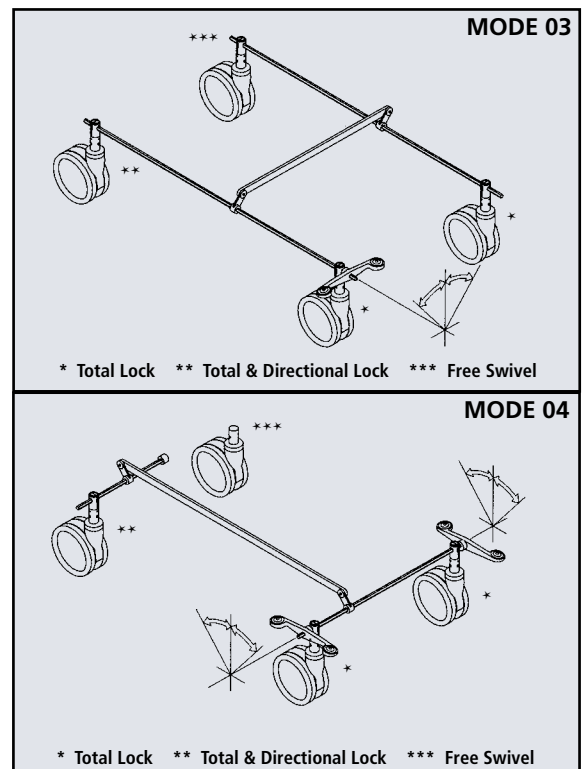

Stem Options

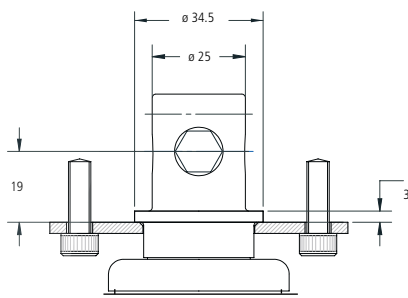

125mm Castors
Total Lock
Free Swivel

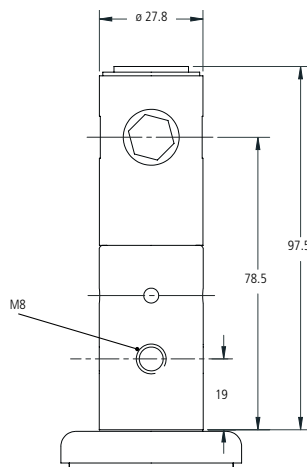

125mm & 150mm Castors
Total Lock
Total & Directional Lock
Free Swivel

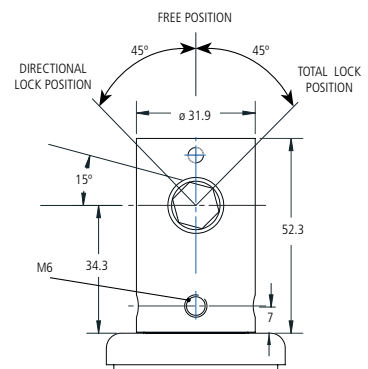

125mm & 150mm Castors
Total Lock
Total & Directional Lock
Free Swivel

Accessories



	Function	Finish	Code
Double Foot Pedal	Universal	Chrome plated	CPD01-00
Single Foot Pedal	Universal	Chrome plated	CPS01-00
Long Link	Universal	Chrome plated	CLL01-00
Short link	Universal	Chrome plated	CLS01-00

Ultimate

Colson Castors pioneered the 'Designer' castor for medical applications with the award-winning TwinTech range. Now this concept has been taken to a new level, with innovative design and materials selection achieving even greater performance, durability and value.

TwinTech Ultimate Castors

Engineered for medical applications, these castors meet the criteria of exceptional reliability, strength, durability and designer looks.

- **Strength:** Die-cast aluminium central body
- **Highly Manoeuvrable:** Ball bearing swivel head and sealed precision bearing wheels
- **Durability and lightness:** Wheels moulded in Nylon 6
- **Smooth, quiet ride:** Hard-wearing polyurethane tyres
- **Hygienic:** All castors can be supplied with SUPPRESS Antimicrobial treatment
- **High quality finish:** RAL 9003 white with grey polyurethane tyres

Solus Castors

Specially engineered for Institutional Applications these are available as free swivel or with total lock or directional lock brakes.

Combi Central-Locking Castors

Recommended for hospital beds and medical equipment, these castors have been designed to offer greater flexibility and improved manoeuvrability.

- **Maintenance-free** braking: no adjustments required.
- **Secure:** Swivel lock and wheel brakes operate independently, improving performance
- **Dynamic braking:** Operating the brake whilst in motion does not damage the mechanism
- **Built-in reliability:** new design has improved performance yet reduced the number of components

SUPPRESS Antimicrobial Treatment

All TwinTech **Ultimate** castor wheels can be treated with SUPPRESS Antimicrobial Compound, which significantly inhibits growth of bacteria, in particular, strains of MRSA, E.coli and C. Diff. This inorganic active ingredient remains within the polymer and is released continuously to the surface of the wheel. An effective way to preserve the life of the wheel, as it is unaffected by chips, scratches and abrasions.



More medical castors from Colson:



TravelAid: Durable 115 and 125mm plastic castors with easy to use push-button brake for all types of ward equipment and furniture.
Load rating: 60kg



MediMaster: Highly-maneuvrable 100mm plastic castors with convenient through-bolt fixing. Ideal for patient lifting and transport applications.
Load rating: 100kg



PlasTech: Versatile 100 and 125mm plastic castors with threaded stem and plate fixings for ward furniture, computer stands, mobile equipment.
Load rating: 80 to 100kg



SingleTech: A range of single wheel designer castors for Medical applications. 100 and 125mm Solus versions with threaded stems and 125 and 150mm Combi castors for central locking applications.
Load rating: 90 up to 150kg



Style: Rugged 125mm swivel and total lock steel castors, under an hygienic and attractive plastic cover, giving style to strength.
Load rating: 100 - 200kg

Colson Castors Limited

Golds Green Works, Bagnall Street, Hill Top
West Bromwich, West Midlands B70 0TZ United Kingdom
Tel: +44 (0)121 556 7221 • Fax: +44 (0)121 502 2658
www.colson-castors.co.uk • e-mail: info@colson-castors.co.uk

